

TECHNICAL SHEET

# DOUBLE ELBOW

# W-WKO

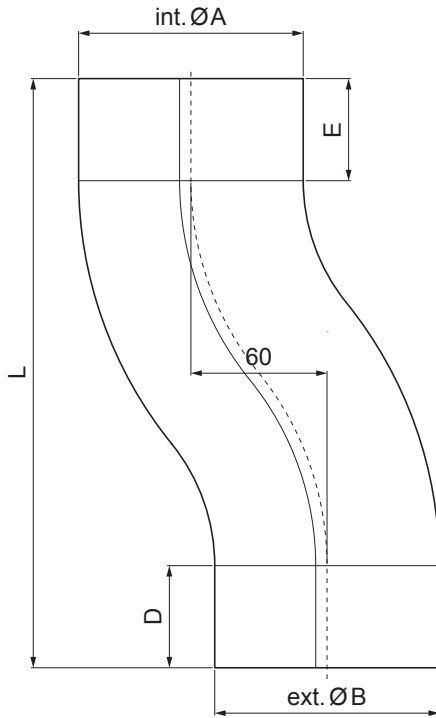

**TM** Aluminium pre-painted – Testa di Moro – RAL 8028

Dimensions [mm]					
Nominal size	$\varnothing A$	$\varnothing B$	D	E	L
80	80,4	79,0	35	35	219
100	100,4	99,0	35	35	240
120	120,4	119,0	40	40	268

INDEX	CHANGE	DATE	SIGNATURE	<b>KJG</b> QUALITY®	Scan code for 3D model
MATERIAL BRAND			W.C.	WEIGHT kg	SCALE
SIZE, SEMI-FINISHED PRODUCTS				STN STANDARD	SORTING NUMBER
AUXILIARY EQUIPMENT				NOTE	POSITION NUMBER
ELABORATED BY Ing. Kluska M.					
TESTED BY					
TECHNOLOGIST		TECHNOLOGIST		OLD DRAWING	DRAWING NUMBER
NAME Double elbow				Number of sheets	W-WKO Sheet

Created: 05.06.2026 20:25:23

Technical changes reserved