

TECHNICAL SHEET

HOOK FASCIA

W.15-WHPK

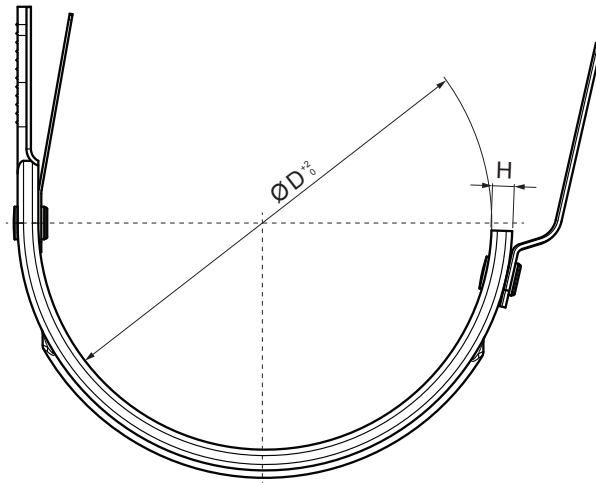
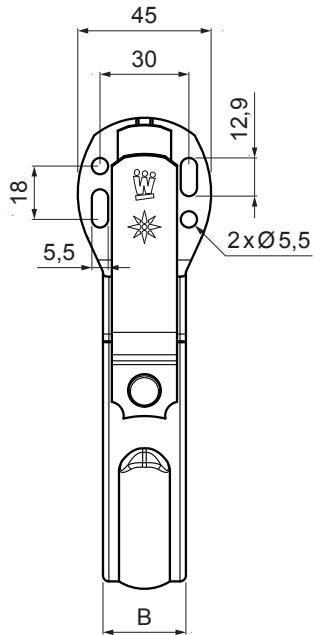

TMM Aluminium pre-painted W.15 – Testa di Moro W.15 – RAL 8028

Dimensions [mm]		
Nominal size	B x H	Ø D
250	28 x 7	105
280	28 x 7	127
333	28 x 7	153
400	28 x 7	192

INDEX	CHANGE	DATE	SIGNATURE	KJG QUALITY®	Scan code for 3D model
MATERIAL BRAND			W.C.	WEIGHT kg	SCALE
SIZE, SEMI-FINISHED PRODUCTS				STN STANDARD	SORTING NUMBER
AUXILIARY EQUIPMENT				NOTE	POSITION NUMBER
ELABORATED BY Ing. Kluska M.					
TESTED BY				OLD DRAWING	DRAWING NUMBER
TECHNOLOGIST			TECHNOLOGIST		
NAME			Hook fascia		
			Number of sheets	W.15-WHPK Sheet	

Created: 06.06.2026 14:43:22

Technical changes reserved