

# TECHNICAL SHEET

## HOOK FASCIA

# W.15-WHPK

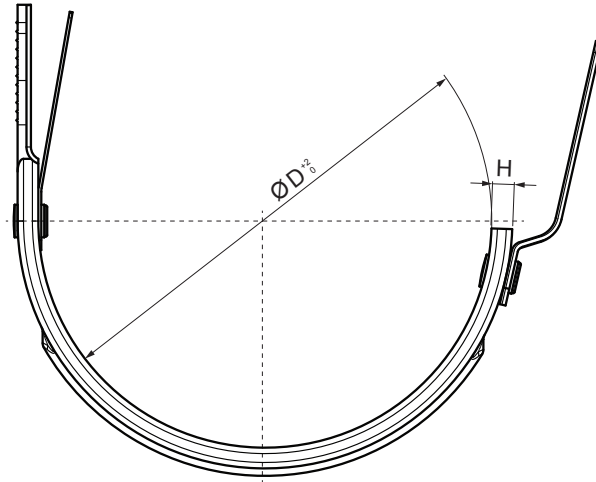
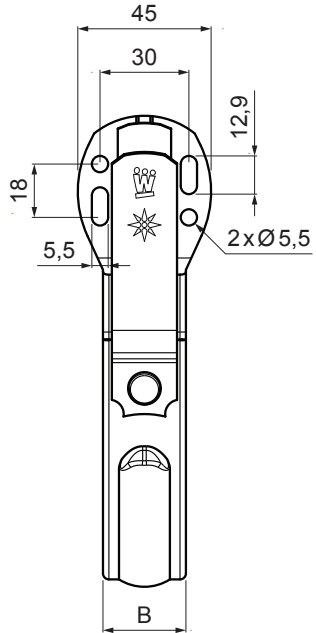

Aluminium pre-painted W.15 – Moss green W.15 – RAL 6005

| Dimensions [mm] |        |     |
|-----------------|--------|-----|
| Nominal size    | B x H  | Ø D |
| 250             | 28 x 7 | 105 |
| 280             | 28 x 7 | 127 |
| 333             | 28 x 7 | 153 |
| 400             | 28 x 7 | 192 |

|                              |        |      |                  |              |                 |
|------------------------------|--------|------|------------------|--------------|-----------------|
| INDEX                        | CHANGE | DATE | SIGNATURE        |              |                 |
|                              |        |      |                  |              |                 |
| MATERIAL BRAND               |        |      | W.C.             | WEIGHT kg    | SCALE           |
| SIZE, SEMI-FINISHED PRODUCTS |        |      |                  | STN STANDARD | SORTING NUMBER  |
| AUXILIARY EQUIPMENT          |        |      |                  | NOTE         | POSITION NUMBER |
| ELABORATED BY Ing. Kluska M. |        |      |                  |              |                 |
| TESTED BY                    |        |      |                  | OLD DRAWING  | DRAWING NUMBER  |
| TECHNOLOGIST                 |        |      | TECHNOLOGIST     |              |                 |
| NAME                         |        |      | Hook fascia      |              |                 |
|                              |        |      | Number of sheets | W.15-WHPK    | Sheet           |

Created: 07.06.2026 21:44:50

Technical changes reserved