

TECHNICAL SHEET

OUTLET

W.15-WKL

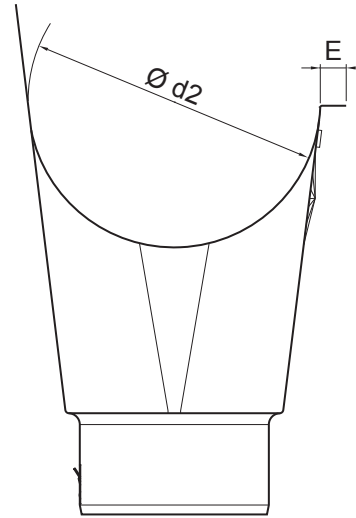
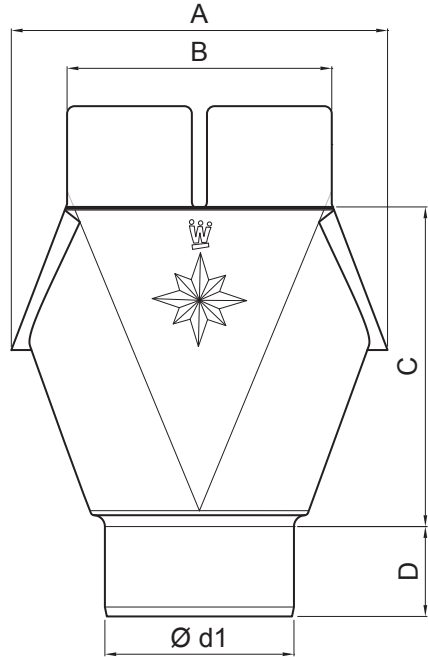

SSM Aluminium pre-painted W.15 – Mouse grey W.15 – RAL 7005

Dimensions [mm]							
Nominal size	Ø d1	Ø d2	A	B	C	D	E
250/80	80	105	140	120	117,5	40	12
280/80	80	127	165	120	143,5	40	12
280/100	100	127	165	120	142,5	45	14
333/80	80	153	185	140	176,5	40	14
333/100	100	153	185	140	170,0	45	14
333/120	120	153	185	140	171,50	50	14
400/120	120	192	210	160	200,4	51	14
400/150	150	192	240	168	205,0	45	14

INDEX CHANGE	DATE	SIGNATURE	KJG QUALITY®	Scan code for 3D model	QR CODE
MATERIAL BRAND					
SIZE, SEMI-FINISHED PRODUCTS					
AUXILIARY EQUIPMENT			STN STANDARD	SORTING NUMBER	
ELABORATED BY Ing. Kluska M.			NOTE		POSITION NUMBER
TESTED BY					
TECHNOLOGIST	TECHNOLOGIST		OLD DRAWING	DRAWING NUMBER	
NAME Outlet			Number of sheets	W.15-WKL	Sheet

Created: 07.06.2026 08:41:28

Technical changes reserved