

TECHNICAL SHEET

HOPPER DESIGN

W.15-WKLZ DE

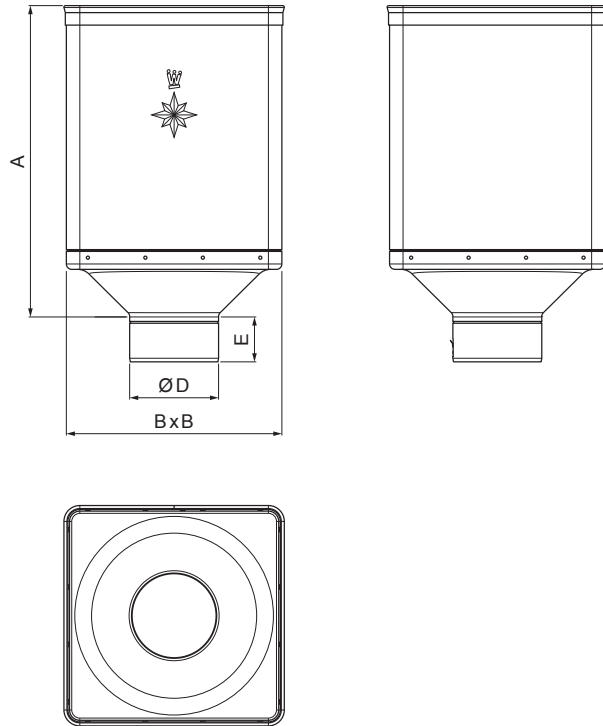

SSM Aluminium pre-painted W.15 – Mouse grey W.15 – RAL 7005

INDEX	CHANGE	DATE	SIGNATURE	KJG QUALITY®	Scan code for 3D model	
MATERIAL BRAND			W.C.	WEIGHT kg	SCALE	
SIZE, SEMI-FINISHED PRODUCTS				STN STANDARD	SORTING NUMBER	
AUXILIARY EQUIPMENT				NOTE	POSITION NUMBER	
ELABORATED BY Ing. Kluska M.						
TESTED BY						
TECHNOLOGIST		TECHNOLOGIST		OLD DRAWING	DRAWING NUMBER	
NAME			Hopper DESIGN		Number of sheets	W.15-WKLZ DE Sheet

Created: 07.06.2026 08:42:35

Technical changes reserved

Dimensions [mm]				
Nominal size	A	B	D	E
80	340	240	79	44
100	336	240	99	50
120	333	240	119	60