

TECHNICAL SHEET ELBOW 72°

W.15-WK

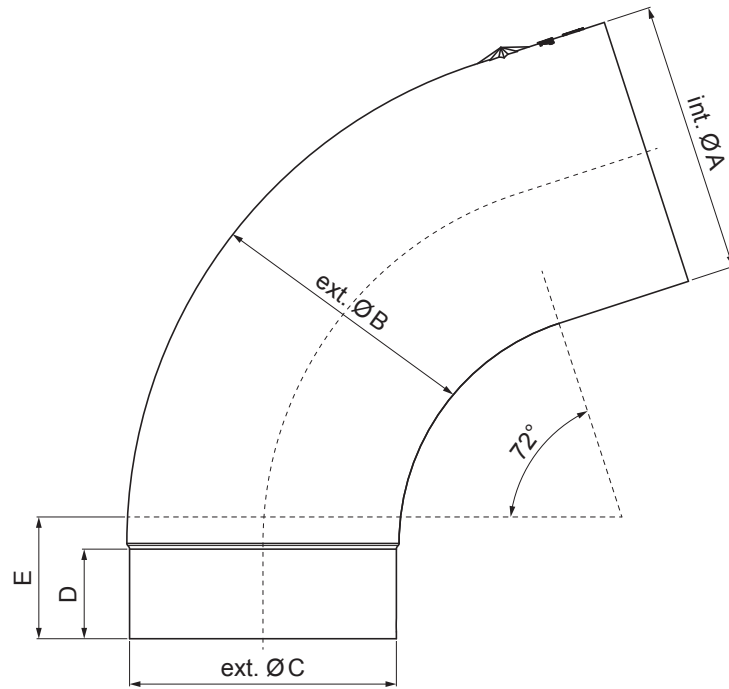

ICM Aluminium pre-painted W.15 – Intense black W.15 – RAL 9005

Dimensions [mm]					
Nominal size	$\varnothing A$	$\varnothing B$	$\varnothing C$	D	E
80	80,4	79,0	76,9	28	40
100	100,4	99,0	96,8	35	50
120	120,3	119,0	116,7	42	60
150	150,3	149,2	148,7	-	75

INDEX	CHANGE	DATE	SIGNATURE	KJG QUALITY®	Scan code for 3D model
MATERIAL BRAND			W.C.	WEIGHT kg	SCALE
SIZE, SEMI-FINISHED PRODUCTS				STN STANDARD	SORTING NUMBER
AUXILIARY EQUIPMENT				NOTE	POSITION NUMBER
ELABORATED BY Ing. Kluska M.					
TESTED BY					
TECHNOLOGIST		TECHNOLOGIST		OLD DRAWING	DRAWING NUMBER
NAME Elbow 72°				Number of sheets	W.15-WK Sheet

Created: 06.06.2026 00:09:55

Technical changes reserved