

TECHNICAL SHEET

DOWNPIPE FLAP WITH SIEVE

W.15-WZVS

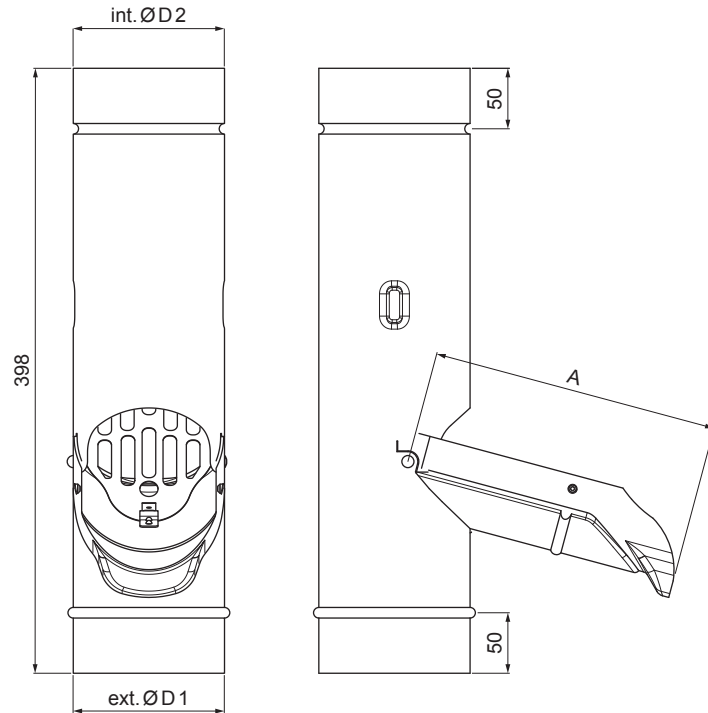

SSM Aluminium pre-painted W.15 – Mouse grey W.15 – RAL 7005

INDEX	CHANGE	DATE	SIGNATURE	KJG QUALITY®	Scan code for 3D model
MATERIAL BRAND			W.C.	WEIGHT kg	SCALE
SIZE, SEMI-FINISHED PRODUCTS				STN STANDARD	SORTING NUMBER
AUXILIARY EQUIPMENT				NOTE	POSITION NUMBER
ELABORATED BY Ing. Kluska M.					
TESTED BY					
TECHNOLOGIST		TECHNOLOGIST		OLD DRAWING	DRAWING NUMBER
NAME Downpipe flap with sieve				Number of sheets	W.15-WZVS Sheet

Created: 07.06.2026 10:21:55

Technical changes reserved

Dimensions [mm]			
Nominal size	A	ØD 1	ØD 2
80	150	80	80
100	190	100	100
120	230	120	120