

TECHNICAL SHEET

DOWNPIPE FLAP WITH SIEVE

W.15-WZVS

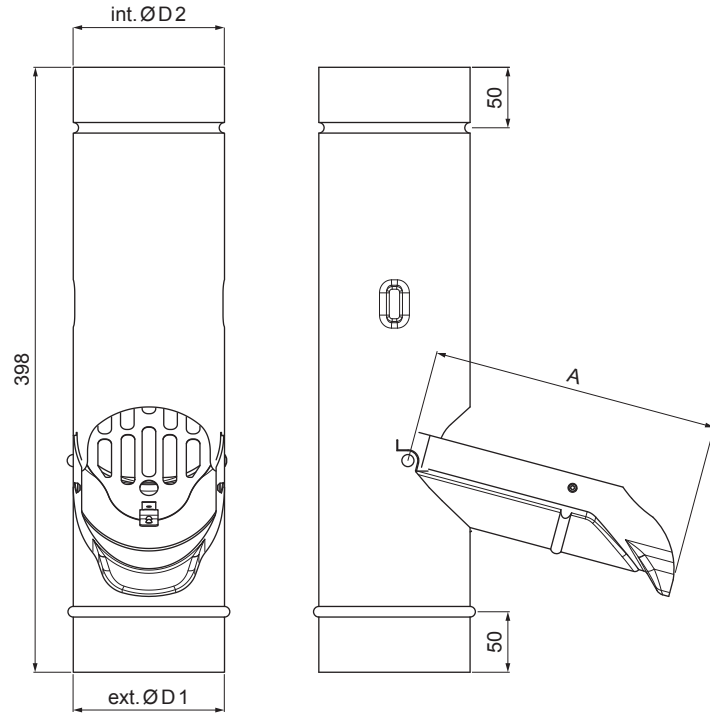

ICM Aluminium pre-painted W.15 – Intense black W.15 – RAL 9005

| Dimensions [mm] | | | |
|-----------------|-----|------|------|
| Nominal size | A | ØD 1 | ØD 2 |
| 80 | 150 | 80 | 80 |
| 100 | 190 | 100 | 100 |
| 120 | 230 | 120 | 120 |

| | | | | | |
|----------------------------------|--------|--------------|-----------|------------------------|------------------------|
| INDEX | CHANGE | DATE | SIGNATURE | KJG QUALITY® | Scan code for 3D model |
| | | | | | |
| MATERIAL BRAND | | | W.C. | WEIGHT kg | SCALE |
| SIZE, SEMI-FINISHED PRODUCTS | | | | STN STANDARD | SORTING NUMBER |
| AUXILIARY EQUIPMENT | | | | NOTE | POSITION NUMBER |
| ELABORATED BY Ing. Kluska M. | | | | | |
| TESTED BY | | | | | |
| TECHNOLOGIST | | TECHNOLOGIST | | OLD DRAWING | DRAWING NUMBER |
| NAME Downpipe flap with sieve | | | | Number of sheets | W.15-WZVS Sheet |

Created: 05.06.2026 23:59:38

Technical changes reserved