

TECHNICAL SHEET

DOWNPIPE FLAP WITH SIEVE

W.15-WZVS

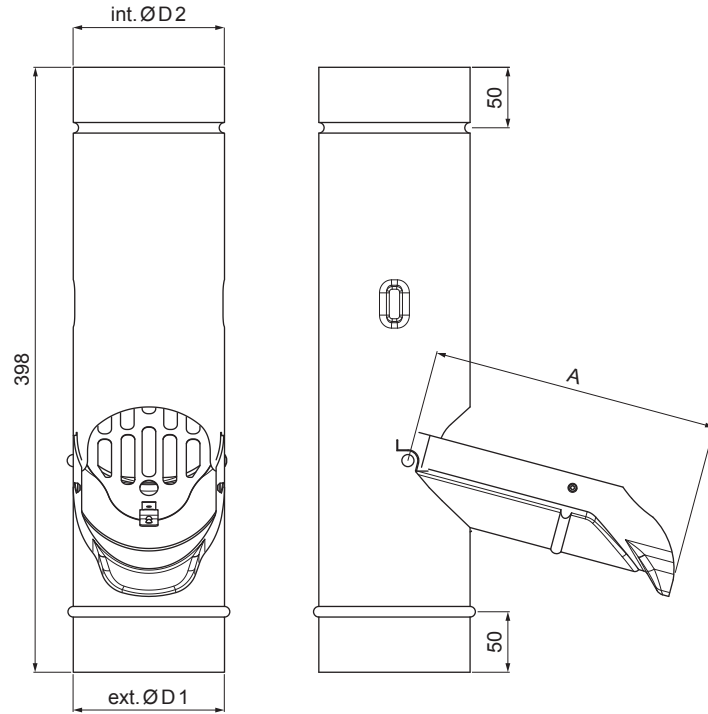

OCM Aluminium pre-painted W.15 – Steel red W.15 – RAL 3009

INDEX	CHANGE	DATE	SIGNATURE	KJG QUALITY®	Scan code for 3D model	
MATERIAL BRAND			W.C.	WEIGHT kg	SCALE	
SIZE, SEMI-FINISHED PRODUCTS				STN STANDARD	SORTING NUMBER	
AUXILIARY EQUIPMENT				NOTE	POSITION NUMBER	
ELABORATED BY Ing. Kluska M.				OLD DRAWING	DRAWING NUMBER	
TESTED BY						
TECHNOLOGIST			TECHNOLOGIST			
NAME			Downpipe flap with sieve		Number of sheets	W.15-WZVS Sheet

Created: 20.01.2026 01:25:15

Technical changes reserved

Dimensions [mm]			
Nominal size	A	ØD1	ØD2
80	150	80	80
100	190	100	100
120	230	120	120