

TECHNICAL SHEET

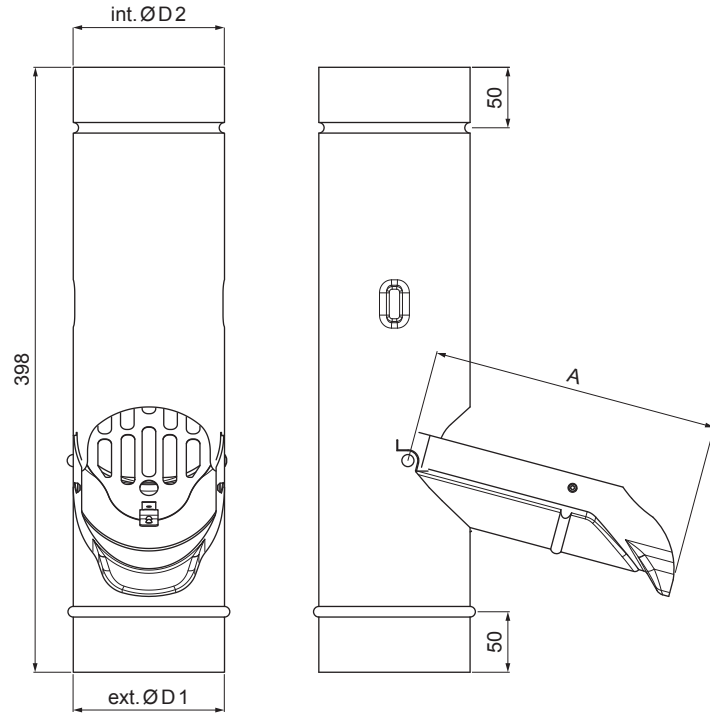

DOWNPIPE FLAP WITH SIEVE

W.15-WZVS



BHM Aluminium pre-painted W.15 – White aluminum W.15 – RAL 9006

Dimensions [mm]			
Nominal size	A	ØD 1	ØD 2
80	150	80	80
100	190	100	100
120	230	120	120

INDEX	CHANGE	DATE	SIGNATURE		
MATERIAL BRAND			W.C.	WEIGHT kg	SCALE
SIZE, SEMI-FINISHED PRODUCTS				STN STANDARD	SORTING NUMBER
AUXILIARY EQUIPMENT				NOTE	POSITION NUMBER
ELABORATED BY Ing. Kluska M.					
TESTED BY					
TECHNOLOGIST		TECHNOLOGIST		OLD DRAWING	DRAWING NUMBER
NAME			Downpipe flap with sieve		
			Number of sheets	W.15-WZVS	Sheet 

Created: 05.06.2026 20:25:47

Technical changes reserved