

TECHNICAL SHEET

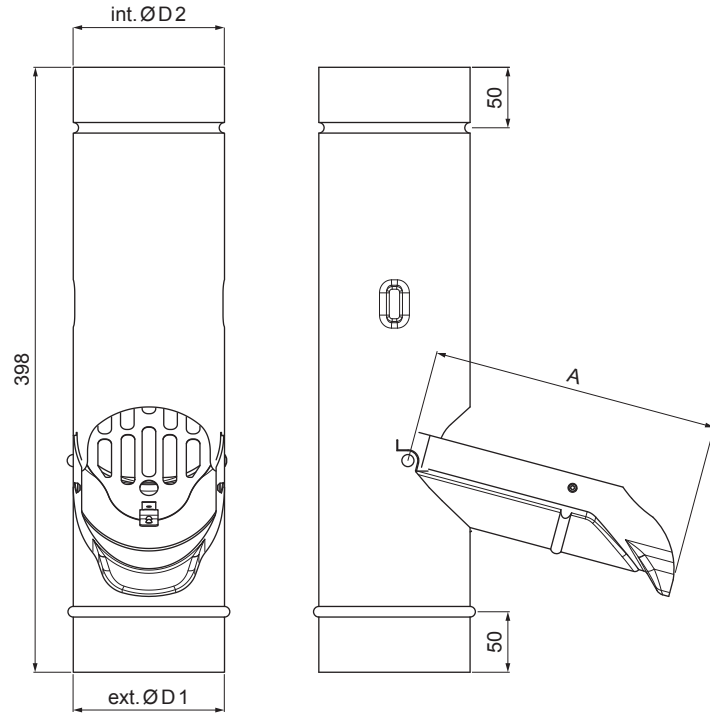



DOWNPIPE FLAP WITH SIEVE

W.15-WZVS



BHTM Aluminium pre-painted W.15 – Grey aluminum W.15 – RAL 9007

Dimensions [mm]			
Nominal size	A	ØD 1	ØD 2
80	150	80	80
100	190	100	100
120	230	120	120

INDEX	CHANGE	DATE	SIGNATURE			
MATERIAL BRAND			W.C.	WEIGHT kg	SCALE	
SIZE, SEMI-FINISHED PRODUCTS					STN STANDARD	SORTING NUMBER
AUXILIARY EQUIPMENT					NOTE	POSITION NUMBER
ELABORATED BY Ing. Kluska M.						
TESTED BY						
TECHNOLOGIST		TECHNOLOGIST	OLD DRAWING		DRAWING NUMBER	
NAME			Downpipe flap with sieve		Number of sheets	W.15-WZVS Sheet 

Created: 07.06.2026 08:42:27

Technical changes reserved