

TECHNICAL SHEET

PROTECTIVE GUTTER PIPE WITH INSPECTION HOLE P-POZR 120

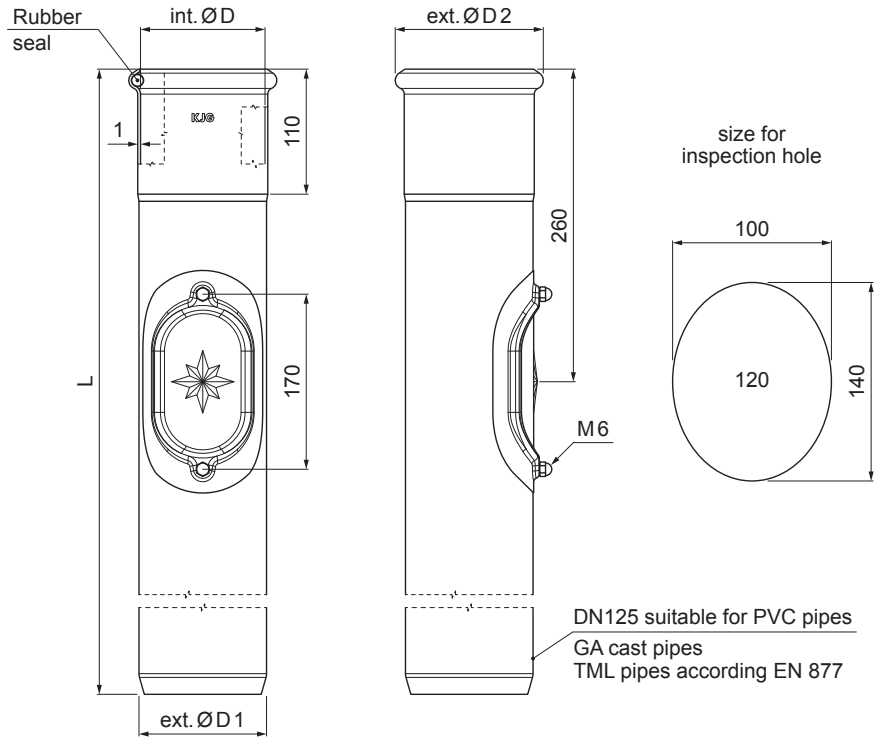

DN125 suitable for PVC pipes
GA cast pipes
TML pipes according EN 877



P Galvanized steel – Natur

Dimensions [mm]				
Nominal size	ØD	ØD1	ØD2	L
120	120	125	143	1000
120	120	125	143	1500

INDEX	CHANGE	DATE	SIGNATURE	KJG QUALITY®	Scan code for 3D model
MATERIAL BRAND			W.C.	WEIGHT kg	SCALE
SIZE, SEMI-FINISHED PRODUCTS				STN STANDARD	SORTING NUMBER
AUXILIARY EQUIPMENT				NOTE	POSITION NUMBER
ELABORATED BY Ing. Kluska M.					
TESTED BY					
TECHNOLOGIST		TECHNOLOGIST		OLD DRAWING	DRAWING NUMBER
NAME			Protective gutter pipe with inspection hole		
			Number of sheets	P-POZR 120	Sheet

Created: 05.06.2026 09:37:25

Technical changes reserved