

TECHNICAL SHEET

GUTTER SQUARE [s=0,55]

PH-PZH D

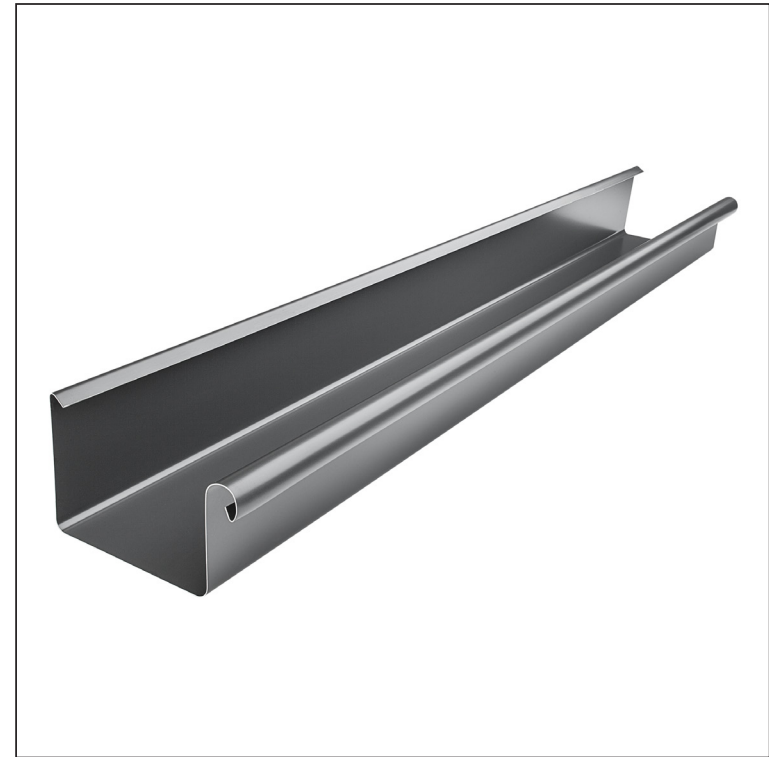

AN Galvanized steel prepainted – Anthracite – RAL 7016

Dimensions [mm]							
Nominal size	S	A	B	C	ØD	E	F min.
200	0,55	42	70	5	16	5	8
250	0,55	55	85	7	18	5	10
333	0,55	75	120	7	20	6	11
400	0,55	90	150	9	22	6	11
500	0,55	110	200	9	22	6	11

INDEX	CHANGE	DATE	SIGNATURE	KJG QUALITY®	Scan code for 3D model	
MATERIAL BRAND			W.C.	WEIGHT kg	SCALE	
SIZE, SEMI-FINISHED PRODUCTS				STN STANDARD	SORTING NUMBER	
AUXILIARY EQUIPMENT				NOTE	POSITION NUMBER	
ELABORATED BY Ing. Kluska M.						
TESTED BY						
TECHNOLOGIST		TECHNOLOGIST		OLD DRAWING	DRAWING NUMBER	
NAME			Gutter square [s=0,55]		Number of sheets	PH-PZH D Sheet

Created: 05.06.2026 04:29:30

Technical changes reserved