

TECHNICAL SHEET

# OUTLET SQUARE/ROUND

# PH-PKLHG

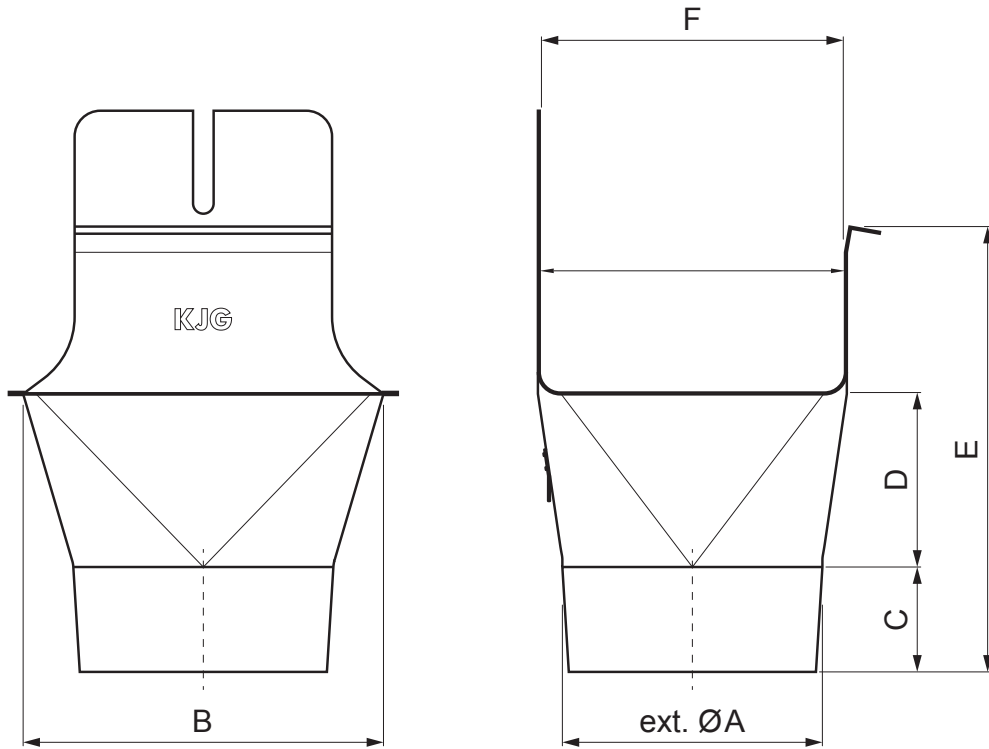

**TM** Galvanized steel pre-painted – Testa di Moro – RAL 8028

Dimensions [mm]						
Nominal size	ØA	B	C	D	E	F
200/60	60	84	28	36	67	70
250/80	80	111	38	46	91	85
333/100	100	140	46	62	126	120
400/120	120	169	55	73	154	150

INDEX	CHANGE	DATE	SIGNATURE	<b>KJG</b> QUALITY®	Scan code for 3D model
MATERIAL BRAND			W.C.	WEIGHT kg	SCALE
SIZE, SEMI-FINISHED PRODUCTS				STN STANDARD	SORTING NUMBER
AUXILIARY EQUIPMENT				NOTE	POSITION NUMBER
ELABORATED BY Ing. Kluska M.					
TESTED BY					
TECHNOLOGIST		TECHNOLOGIST		OLD DRAWING	DRAWING NUMBER
NAME			PH-PKLHG		
Outlet square/round			Number of sheets		Sheet

Created: 06.06.2026 04:40:04

Technical changes reserved