

TECHNICAL SHEET

OUTLET SQUARE/ROUND

PH-PKLHG

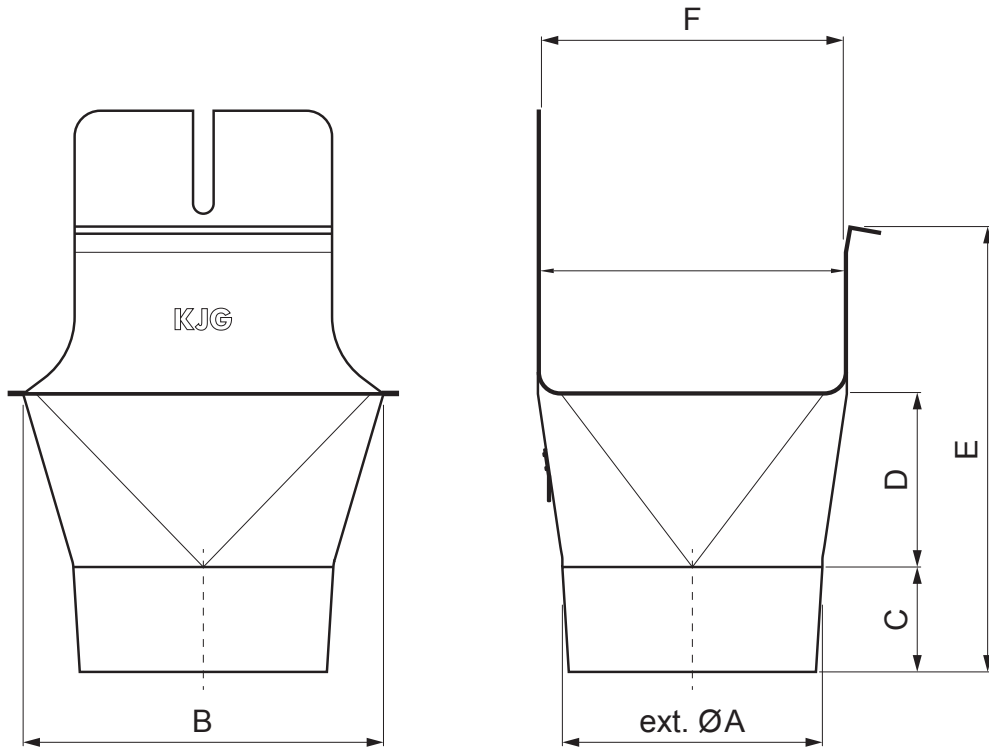

OC Galvanized steel prepainted – Steel red – RAL 3009

Dimensions [mm]						
Nominal size	ØA	B	C	D	E	F
200/60	60	84	28	36	67	70
250/80	80	111	38	46	91	85
333/100	100	140	46	62	126	120
400/120	120	169	55	73	154	150

INDEX	CHANGE	DATE	SIGNATURE	KJG QUALITY®	Scan code for 3D model	
MATERIAL BRAND			W.C.	WEIGHT kg	SCALE	
SIZE, SEMI-FINISHED PRODUCTS			STN STANDARD		SORTING NUMBER	
AUXILIARY EQUIPMENT			NOTE		POSITION NUMBER	
ELABORATED BY Ing. Kluska M.			OLD DRAWING		DRAWING NUMBER	
TESTED BY			NAME		PH-PKLHG	
TECHNOLOGIST			Outlet square/round		Number of sheets	Sheet

Created: 07.06.2026 01:56:49

Technical changes reserved