

TECHNICAL SHEET

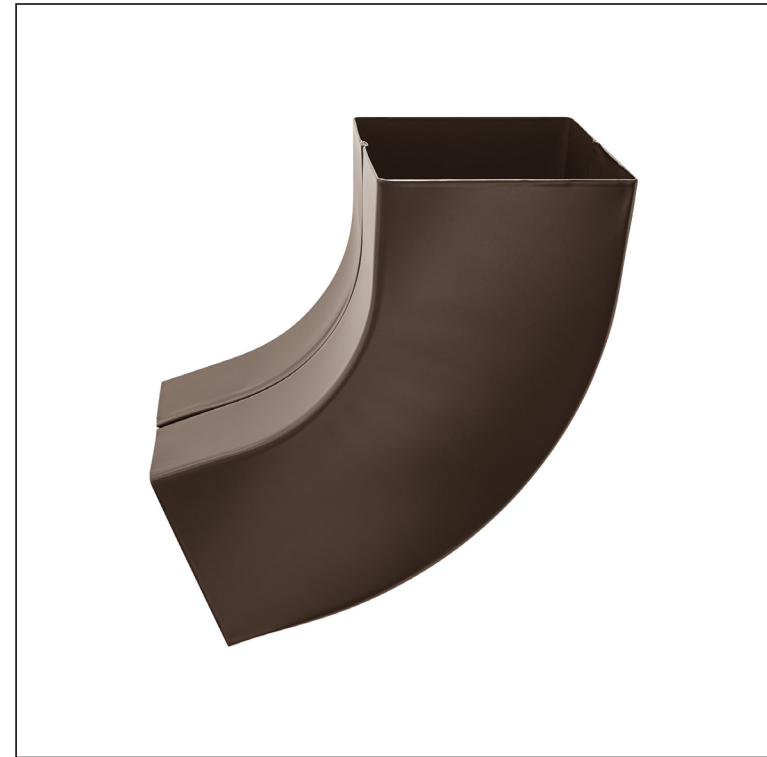

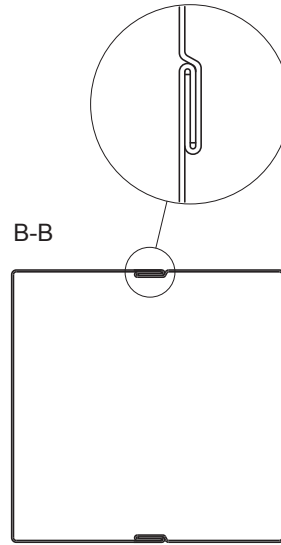

ELBOW SQUARE 72°

PH-PKH



TM Galvanized steel pre-painted – Testa di Moro – RAL 8028

Dimensions [mm]			
Nominal size	AxA	A1xA1	L
80/80	78 x 78	83 x 83	210
100/100	98 x 98	103 x 103	270

INDEX	CHANGE	DATE	SIGNATURE			
MATERIAL BRAND			W.C.	WEIGHT kg	SCALE	
SIZE, SEMI-FINISHED PRODUCTS					STN STANDARD	SORTING NUMBER
AUXILIARY EQUIPMENT					NOTE	POSITION NUMBER
ELABORATED BY Ing. Kluska M.					OLD DRAWING	DRAWING NUMBER
TESTED BY						
TECHNOLOGIST		TECHNOLOGIST			Number of sheets	PH-PKH Sheet 
NAME			Elbow square 72°			

Created: 06.06.2026 03:37:19

Technical changes reserved

TECHNICAL SHEET

ELBOW SQUARE 72°

PH-PKH

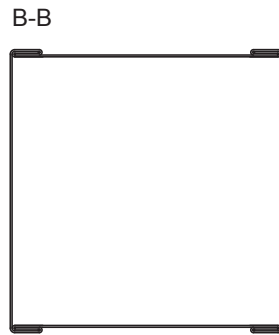
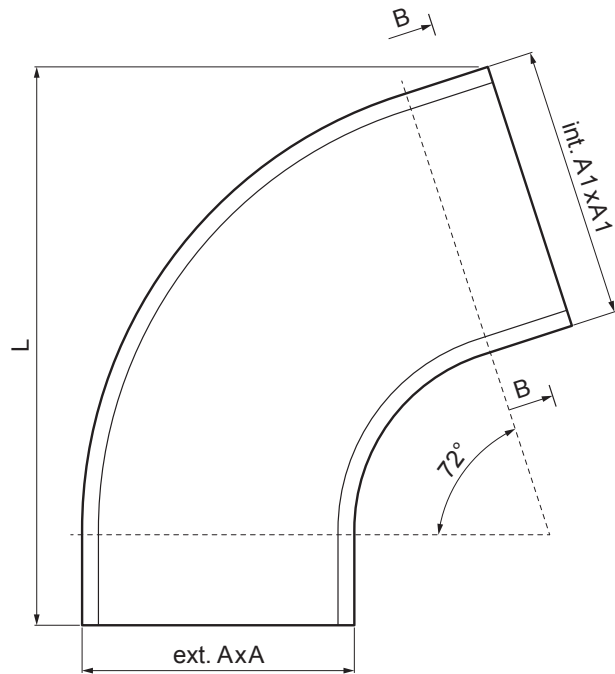

TM Galvanized steel pre-painted – Testa di Moro – RAL 8028

INDEX	CHANGE	DATE	SIGNATURE	KJG QUALITY®	Scan code for 3D model
MATERIAL BRAND			W.C.	WEIGHT kg	SCALE
SIZE, SEMI-FINISHED PRODUCTS				STN STANDARD	SORTING NUMBER
AUXILIARY EQUIPMENT				NOTE	POSITION NUMBER
ELABORATED BY Ing. Kluska M.				OLD DRAWING	DRAWING NUMBER
TESTED BY					
TECHNOLOGIST		TECHNOLOGIST		Number of sheets	PH-PKH Sheet
NAME			Elbow square 72°		

Created: 06.06.2026 03:37:19

Technical changes reserved

Dimensions [mm]			
Nominal size	AxA	A1xA1	L
120/120	118 x 118	123 x 123	300
150/150	148 x 148	153 x 153	350