

TECHNICAL SHEET

GUTTER SQUARE [s=0,70]

WH-WZHD

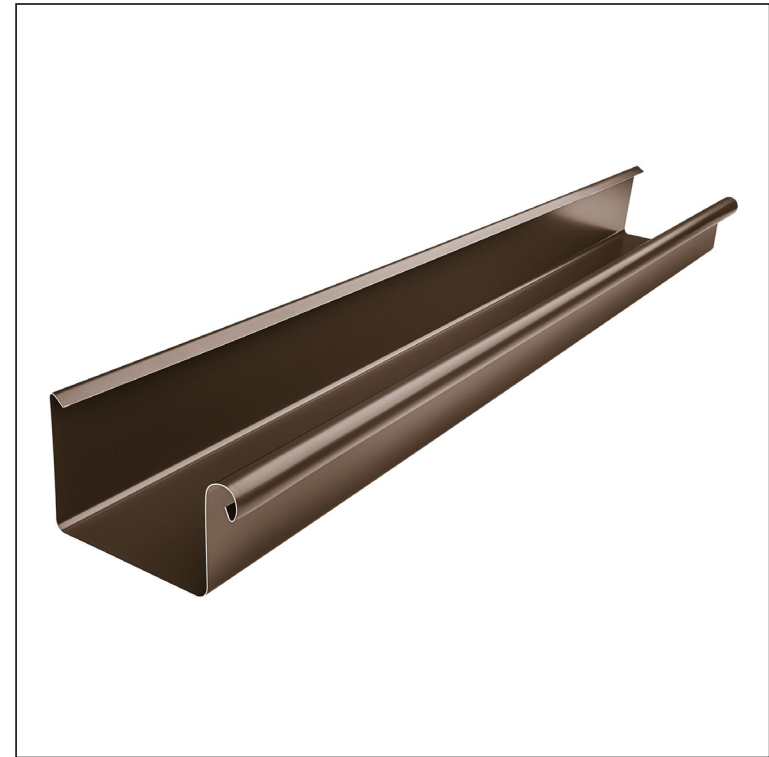

TM Aluminium pre-painted – Testa di Moro – RAL 8028

INDEX	CHANGE	DATE	SIGNATURE	KJG QUALITY®	Scan code for 3D model	
MATERIAL BRAND			W.C.	WEIGHT kg	SCALE	
SIZE, SEMI-FINISHED PRODUCTS				STN STANDARD	SORTING NUMBER	
AUXILIARY EQUIPMENT				NOTE	POSITION NUMBER	
ELABORATED BY Ing. Kluska M.				OLD DRAWING	DRAWING NUMBER	
TESTED BY						
TECHNOLOGIST			TECHNOLOGIST			
NAME			Gutter square [s=0,70]		Number of sheets	WH-WZHD Sheet

Created: 06.06.2026 17:40:01

Technical changes reserved

Dimensions [mm]							
Nominal size	S	A	B	C	ØD	E	F min.
250	0,70	55	85	7	18	5	10
333	0,70	75	120	7	20	6	11
400	0,70	90	150	9	22	6	11