

# TECHNICAL SHEET

## HOOK FASCIA

# P-PHPK

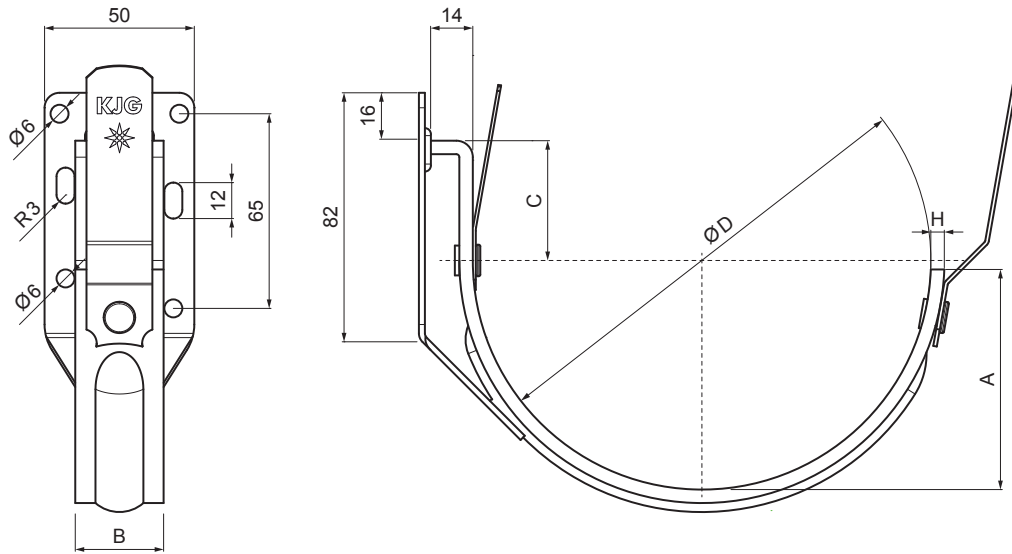

**TZ** Galvanized steel prepainted – Reseda green – RAL 6011

Dimensions [mm]				
Nominal size	A	B x H	C	Ø D
200	37	25 x 4	35	80
250	50	25 x 4	35	105
280	61	25 x 4	35	127
333	74	25 x 5	40	153
400	74	30 x 5	40	192

INDEX	CHANGE	DATE	SIGNATURE	<b>KJG</b> QUALITY®	Scan code for 3D model	
MATERIAL BRAND			W.C.	WEIGHT kg	SCALE	
SIZE, SEMI-FINISHED PRODUCTS				STN STANDARD	SORTING NUMBER	
AUXILIARY EQUIPMENT				NOTE	POSITION NUMBER	
ELABORATED BY Ing. Kluska M.						
TESTED BY						
TECHNOLOGIST		TECHNOLOGIST		OLD DRAWING	DRAWING NUMBER	
NAME			Hook fascia		Number of sheets	P-PHPK Sheet

Created: 04.06.2026 06:58:10

Technical changes reserved