

TECHNICAL SHEET

BARGE FLASHING

UNI-PKLE

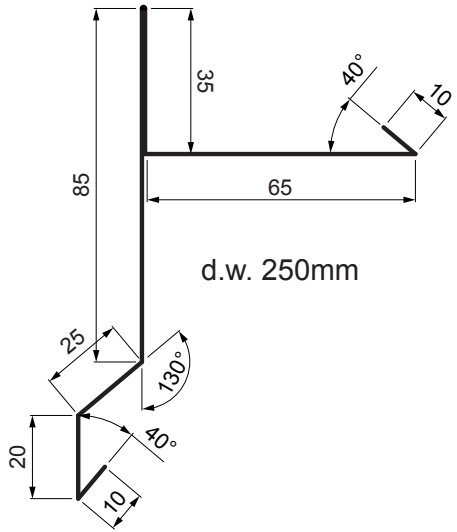

d.w. 250mm

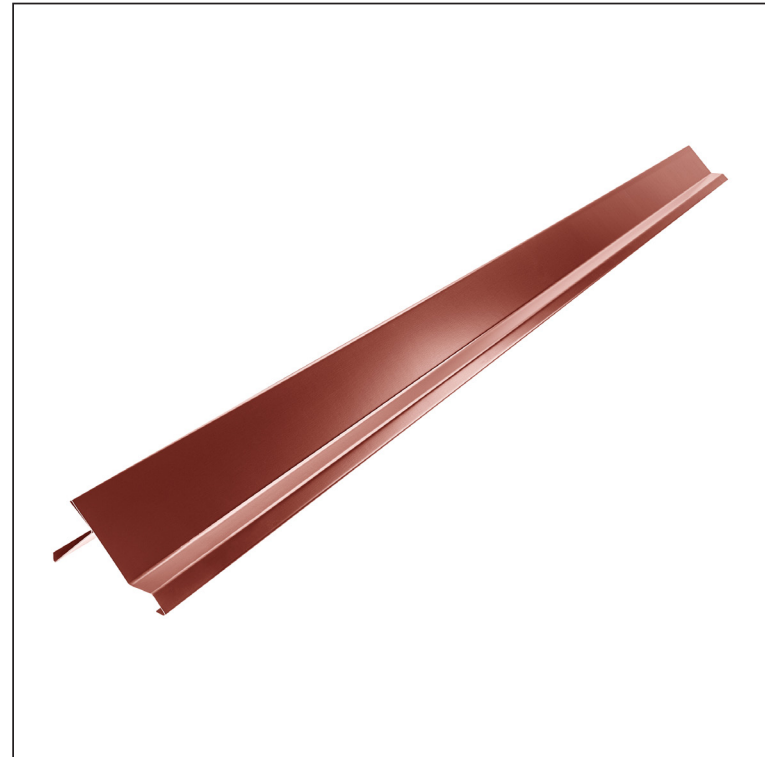

DETAIL:

- 1. barge flashing
- 2. farmer screw 4,8x20
- 3. metal roofing
- 4. roof battens
- 5. battens / air gap
- 6. rafter
- 7. gable plate
- 8. foil / waterproofing insulation

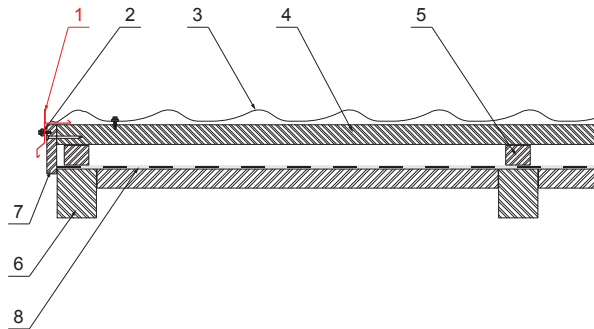

OC Galvanized steel prepainted – Steel red – RAL 3009

INDEX	CHANGE	DATE	SIGNATURE	KJG QUALITY®	Scan code for 3D model
MATERIAL BRAND			W.C.	WEIGHT kg	SCALE
SIZE, SEMI-FINISHED PRODUCTS				STN STANDARD	SORTING NUMBER
AUXILIARY EQUIPMENT				NOTE	POSITION NUMBER
ELABORATED BY Ing. Kluska M.					
TESTED BY		TECHNOLOGIST		OLD DRAWING	DRAWING NUMBER
NAME			UNI-PKLE		
Barge flashing			Number of sheets		Sheet

Created: 04.06.2026 05:23:44

Technical changes reserved

Dimensions	
Nominal dimension [mm]	Length [m]
250	2,0
250	3,0