

TECHNICAL SHEET OUTLET

P-PKL

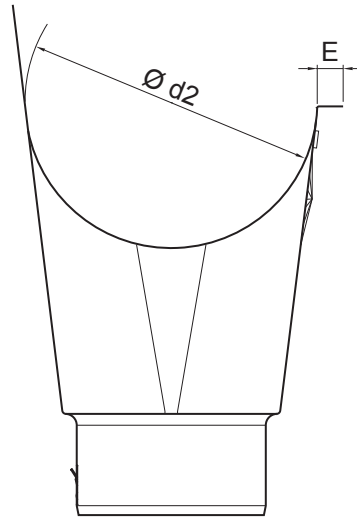
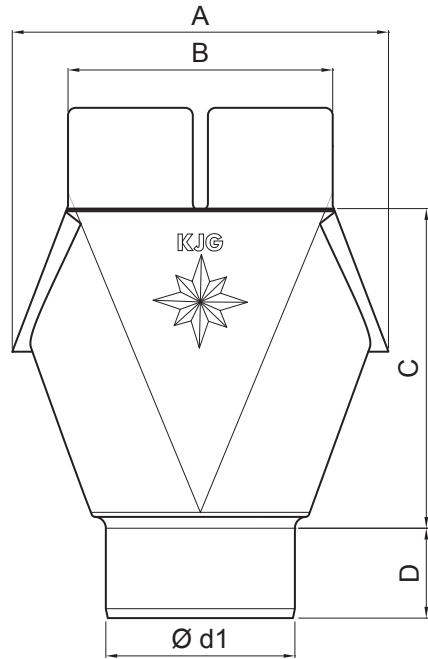

BH Galvanized steel prepainted – White aluminum – RAL 9006

Dimensions [mm]							
Nominal size	Ø d1	Ø d2	A	B	C	D	E
200/60	60	80	115	80	99,5	30	12
250/60	60	105	140	100	127,5	30	12
250/80	80	105	140	120	117,5	40	12
280/80	80	127	165	120	143,5	40	12
280/100	100	127	165	120	142,5	45	14
333/80	80	153	185	140	176,5	40	14
333/100	100	153	185	140	170,0	45	14
333/120	120	153	185	140	171,50	50	14
400/100	100	192	210	160	205,0	45	14
400/120	120	192	210	160	200,4	51	14
400/150	150	192	240	168	205,0	45	14

INDEX	CHANGE	DATE	SIGNATURE	KJG QUALITY®	Scan code for 3D model	
MATERIAL BRAND			W.C.	WEIGHT kg	SCALE	
SIZE, SEMI-FINISHED PRODUCTS			STN STANDARD		SORTING NUMBER	
AUXILIARY EQUIPMENT			NOTE		POSITION NUMBER	
ELABORATED BY Ing. Kluska M.			OLD DRAWING		DRAWING NUMBER	
TESTED BY			NAME		Number of sheets	
TECHNOLOGIST			TECHNOLOGIST		P-PKL Sheet	
NAME			Outlet		Sheet	

Created: 07.06.2026 09:06:27

Technical changes reserved