

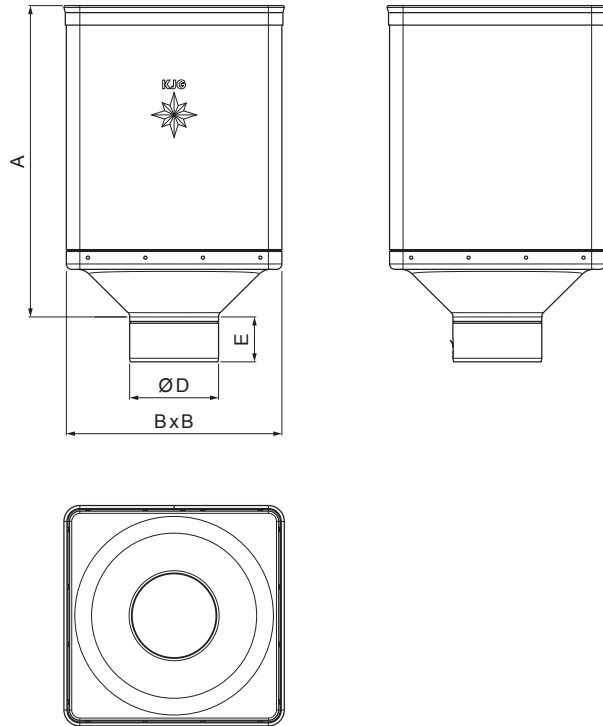

# TECHNICAL SHEET HOPPER DESIGN

# P-PKLZ DE



**MZ** Galvanized steel prepainted – Moss green – RAL 6005

INDEX	CHANGE	DATE	SIGNATURE	<b>KJG</b> QUALITY®	Scan code for 3D model 
MATERIAL BRAND			W.C.	WEIGHT kg	SCALE
SIZE, SEMI-FINISHED PRODUCTS				STN STANDARD	SORTING NUMBER
AUXILIARY EQUIPMENT				NOTE	POSITION NUMBER
ELABORATED BY Ing. Kluska M.					
TESTED BY					
TECHNOLOGIST		TECHNOLOGIST		OLD DRAWING	DRAWING NUMBER
NAME Hopper DESIGN				Number of sheets	P-PKLZ DE Sheet 

Created: 06.06.2026 18:42:54

Technical changes reserved

Dimensions [mm]				
Nominal size	A	B	D	E
80	340	240	79	44
100	336	240	99	50
120	333	240	119	60