

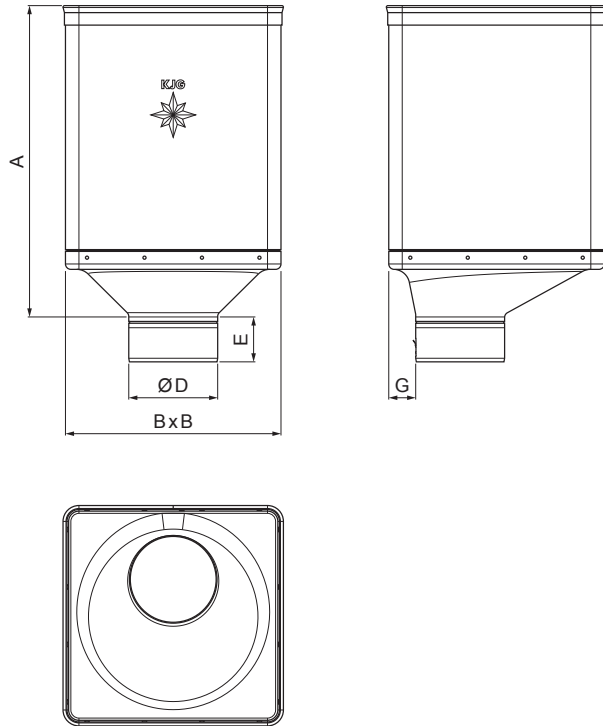



TECHNICAL SHEET

HOPPER DESIGN ECCENTRIC

P-PKLZ DX



BH Galvanized steel pre-painted – White aluminum – RAL 9006

INDEX	CHANGE	DATE	SIGNATURE			
MATERIAL BRAND			W.C.	WEIGHT kg	SCALE	
SIZE, SEMI-FINISHED PRODUCTS			STN STANDARD		SORTING NUMBER	
AUXILIARY EQUIPMENT			NOTE		POSITION NUMBER	
ELABORATED BY Ing. Kluska M.			OLD DRAWING		DRAWING NUMBER	
TESTED BY			DRAWING NUMBER		DRAWING NUMBER	
TECHNOLOGIST			DRAWING NUMBER		DRAWING NUMBER	
NAME			Hopper DESIGN ECCENTRIC		P-PKLZ DX	
			Number of sheets		Sheet 	

Created: 05.06.2026 20:36:44

Technical changes reserved

Dimensions [mm]					
Nominal size	A	B	D	E	G
80	340	240	79	44	30
100	336	240	99	50	30
120	333	240	119	60	30