

TECHNICAL SHEET

# HOPPER DESIGN ECCENTRIC

# P-PKLZ DX

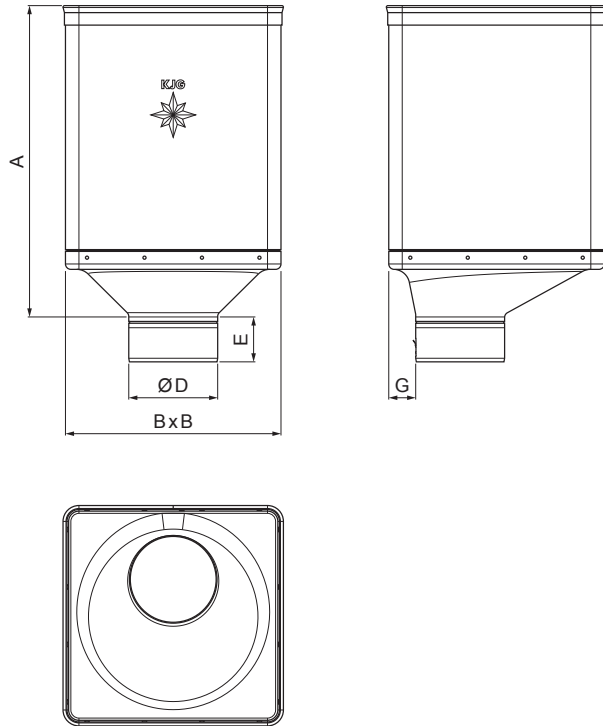

**MM** Galvanized steel pre-painted – Metallic copper – RAL extra

Dimensions [mm]					
Nominal size	A	B	D	E	G
80	340	240	79	44	30
100	336	240	99	50	30
120	333	240	119	60	30

INDEX	CHANGE	DATE	SIGNATURE	<b>KJG</b> QUALITY®	Scan code for 3D model
MATERIAL BRAND			W.C.	WEIGHT kg	SCALE
SIZE, SEMI-FINISHED PRODUCTS				STN STANDARD	SORTING NUMBER
AUXILIARY EQUIPMENT				NOTE	POSITION NUMBER
ELABORATED BY Ing. Kluska M.					
TESTED BY					
TECHNOLOGIST		TECHNOLOGIST		OLD DRAWING	DRAWING NUMBER
NAME Hopper DESIGN ECCENTRIC				Number of sheets	P-PKLZ DX Sheet

Created: 06.06.2026 06:29:10

Technical changes reserved