

TECHNICAL SHEET

EPDM RUBBER SEAL FOR HOPPER

P-PKLZ T

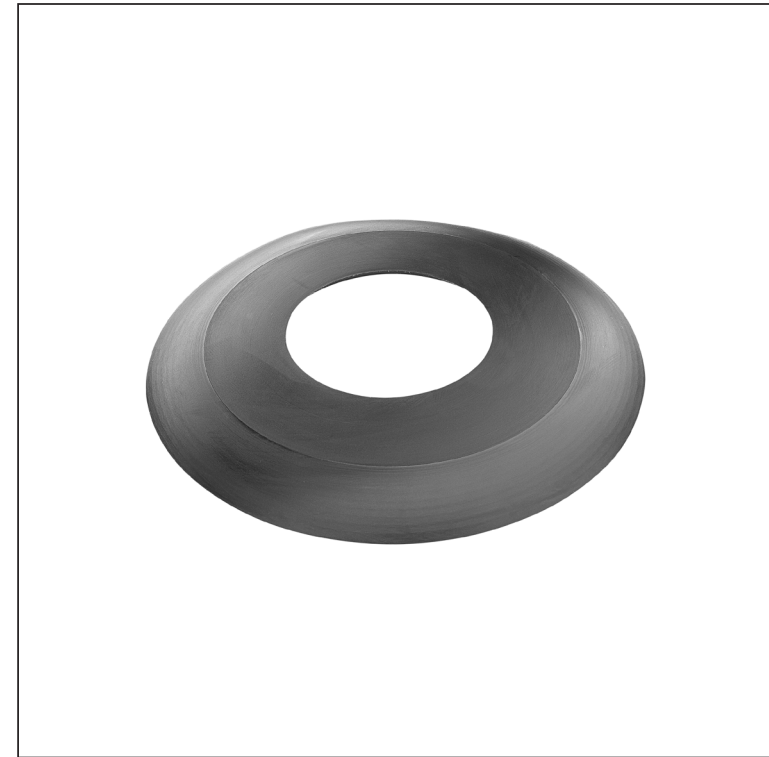
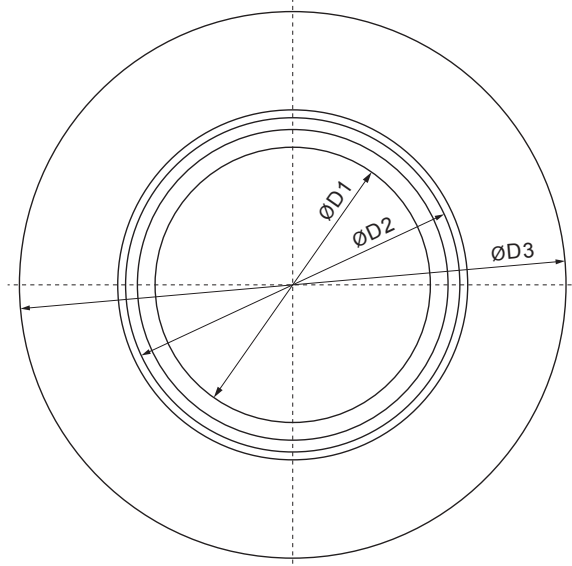
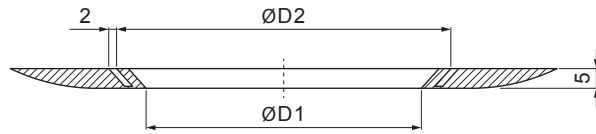

IC EPDM – Intense black – RAL 9005

Dimensions [mm]			
Nominal size	ØD1	ØD2	ØD3
70-85	70	85	140
100-110	90	95	140
110-125	100	120	169

INDEX	CHANGE	DATE	SIGNATURE	KJG QUALITY®	Scan code for 3D model
MATERIAL BRAND			W.C.	WEIGHT kg	SCALE
SIZE, SEMI-FINISHED PRODUCTS				STN STANDARD	SORTING NUMBER
AUXILIARY EQUIPMENT				NOTE	POSITION NUMBER
ELABORATED BY Ing. Kluska M.					
TESTED BY					
TECHNOLOGIST		TECHNOLOGIST		OLD DRAWING	DRAWING NUMBER
NAME			EPDM rubber seal for hopper		
			Number of sheets	P-PKLZ T	Sheet

Created: 06.06.2026 02:53:47

Technical changes reserved

TECHNICAL SHEET

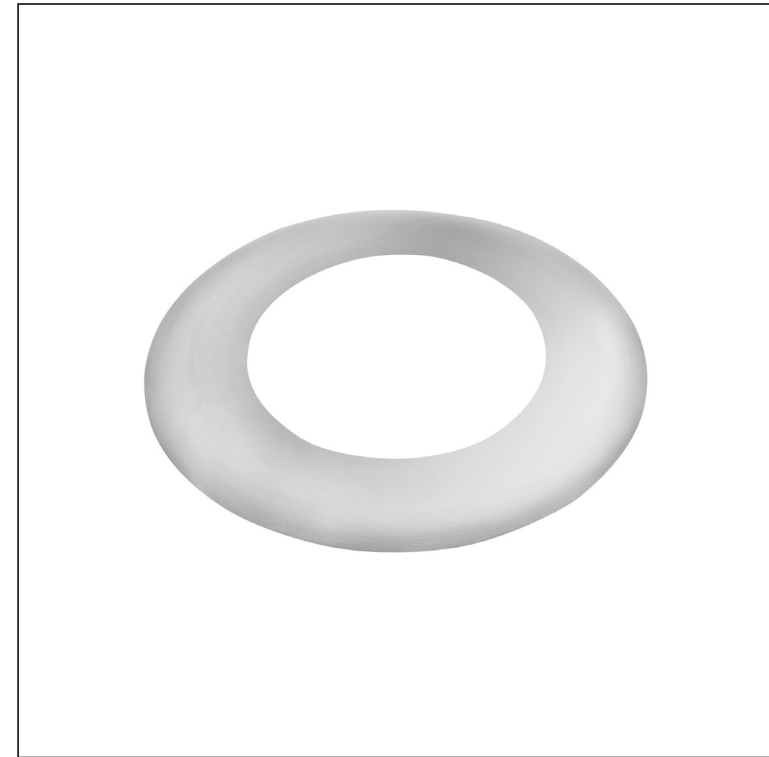
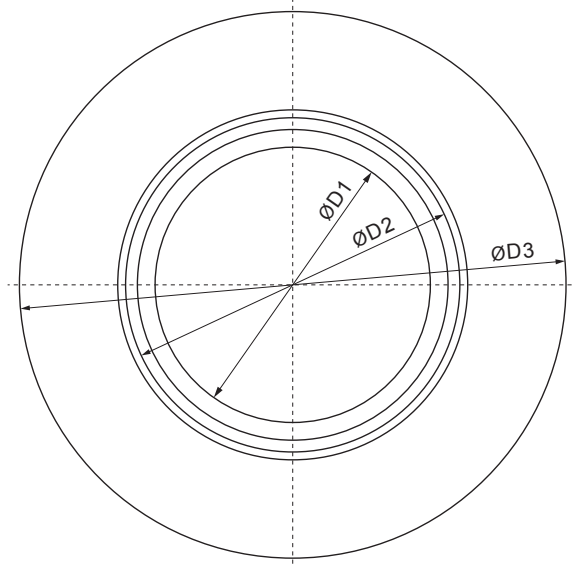
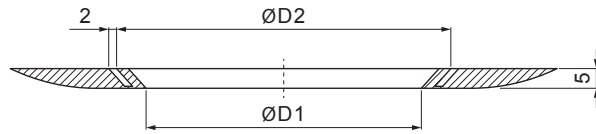

EPDM RUBBER SEAL FOR HOPPER

P-PKLZ T



PS EPDM – Dusty Grey – RAL 7037

Dimensions [mm]			
Nominal size	ØD1	ØD2	ØD3
70-85	70	85	140
100-110	90	95	140
110-125	100	120	169

INDEX	CHANGE	DATE	SIGNATURE		
MATERIAL BRAND			W.C.	WEIGHT kg	SCALE
SIZE, SEMI-FINISHED PRODUCTS				STN STANDARD	SORTING NUMBER
AUXILIARY EQUIPMENT				NOTE	POSITION NUMBER
ELABORATED BY Ing. Kluska M.					
TESTED BY					
TECHNOLOGIST		TECHNOLOGIST		OLD DRAWING	DRAWING NUMBER
NAME			P-PKLZ T		
EPDM rubber seal for hopper			Number of sheets		Sheet 

Created: 06.06.2026 02:53:47

Technical changes reserved