

TECHNICAL SHEET

ALUMINUM CALOTTE WASHER TR 18

TR-ORK TR18

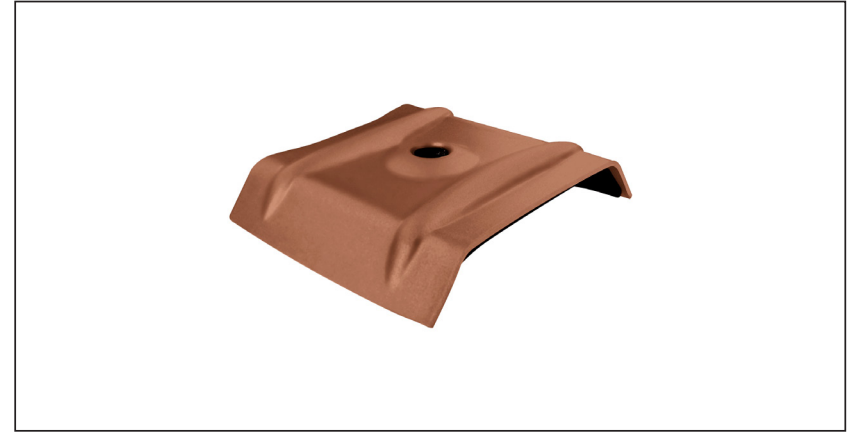
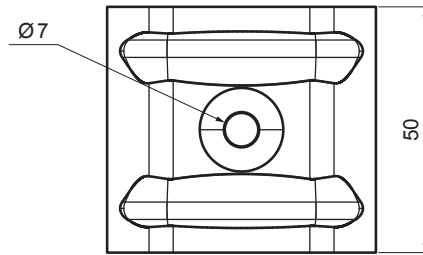
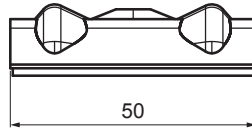
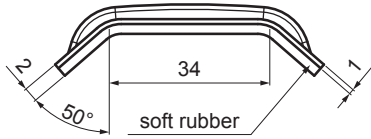

VALUES FOR DETERMINING THE CORRECT CALLOTE:

- width of upper wave (mm)
- angle α (°)
- or**
- width of upper wave (mm)
- profile height (mm)
- clear width of upper wave (mm)

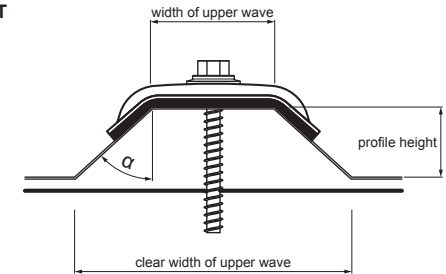

USE:
- to fix TR in its upper wave

FEATURES:
- increases stability
- security of attachment

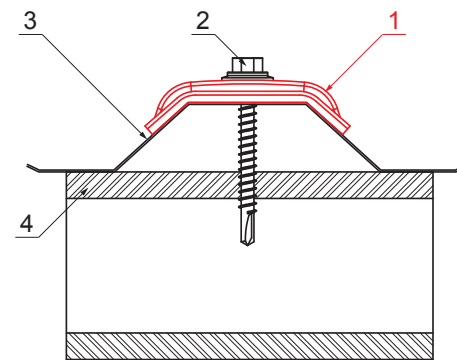
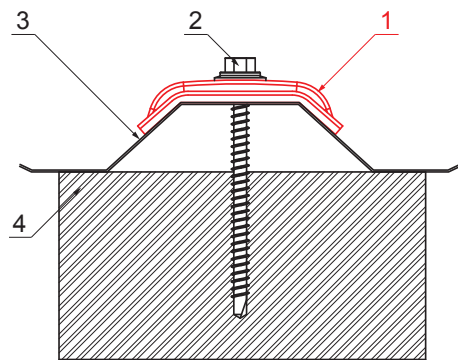

- DETAIL:**
1. aluminum calotte washer TR
 2. galvanized TR screw for wood
 3. trapezoidal sheet roof
 4. wood

- DETAIL:**
1. aluminum calotte washer TR
 2. galvanized TR screw for steel
 3. trapezoidal sheet roof
 4. steel

MH Aluminium preprinted – Copper brown – RAL 8004

INDEX	CHANGE	DATE	SIGNATURE	KJG QUALITY	Scan code for 3D model	
MATERIAL BRAND			W.C.	WEIGHT kg	SCALE	
SIZE, SEMI-FINISHED PRODUCTS				STN STANDARD	SORTING NUMBER	
AUXILIARY EQUIPMENT				NOTE	POSITION NUMBER	
ELABORATED BY Ing. Kluska M.						
TESTED BY						
TECHNOLOGIST		TECHNOLOGIST		OLD DRAWING	DRAWING NUMBER	
NAME				Aluminum calotte washer TR 18		
				Number of sheets	TR-ORK TR18 Sheet	

Created: 04.12.2025 13:13:23

Technical changes reserved