

TECHNICAL SHEET

ALUMINUM CALOTTE WASHER TR 35

TR-ORK TR35

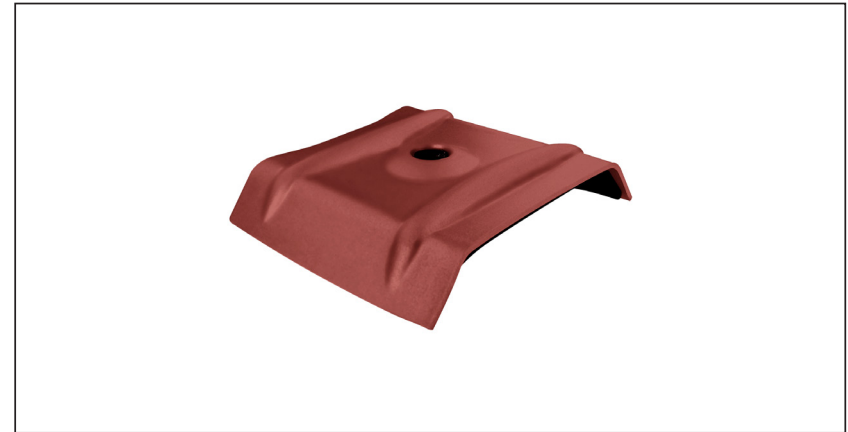
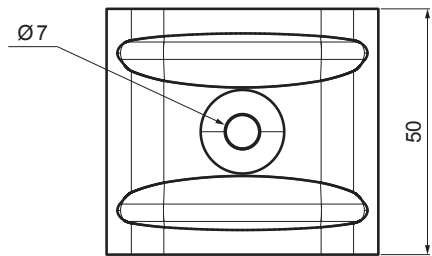
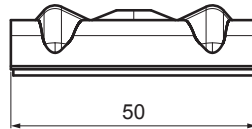
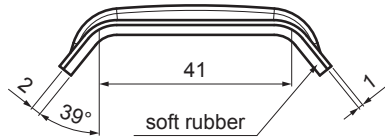

VALUES FOR DETERMINING THE CORRECT CALLOTE:

- width of upper wave (mm)
- angle α (°)
- or**
- width of upper wave (mm)
- profile height (mm)
- clear width of upper wave (mm)

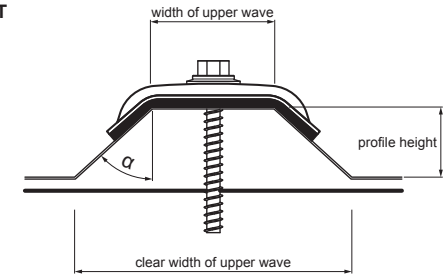

USE:
- to fix TR in its upper wave

FEATURES:
- increases stability
- security of attachment

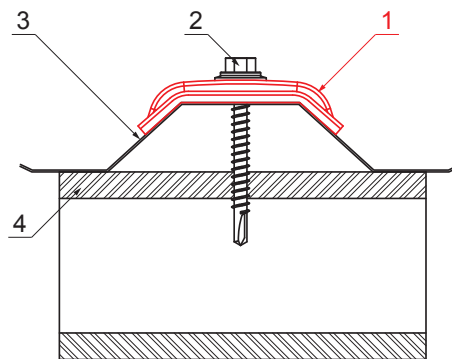
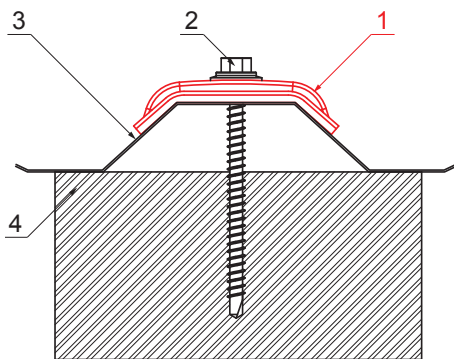

- DETAIL:**
1. aluminum calotte washer TR
 2. galvanized TR screw for wood
 3. trapezoidal sheet roof
 4. wood

- DETAIL:**
1. aluminum calotte washer TR
 2. galvanized TR screw for steel
 3. trapezoidal sheet roof
 4. steel

OC Aluminium preprinted – Steel red – RAL 3009

INDEX	CHANGE	DATE	SIGNATURE	KJG QUALITY	Scan code for 3D model	
MATERIAL BRAND			W.C.	WEIGHT kg	SCALE	
SIZE, SEMI-FINISHED PRODUCTS			STN STANDARD		SORTING NUMBER	
AUXILIARY EQUIPMENT			NOTE		POSITION NUMBER	
ELABORATED BY Ing. Kluska M.						
TESTED BY			OLD DRAWING		DRAWING NUMBER	
TECHNOLOGIST			TECHNOLOGIST			
NAME			Aluminum calotte washer TR 35		TR-ORK TR35	
			Number of sheets		Sheet	

Created: 07.06.2026 04:47:53

Technical changes reserved