

# TECHNICAL SHEET

## MOUNTING PLATE BASIC

# FALZ-HEU MP ZPL

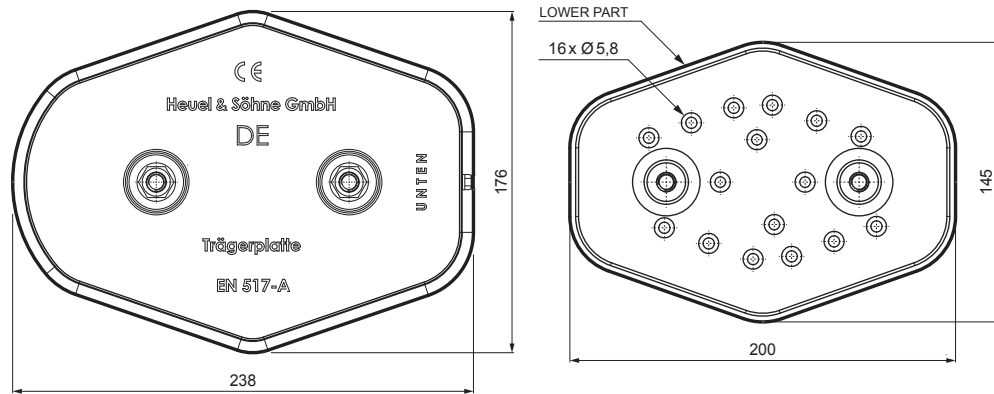
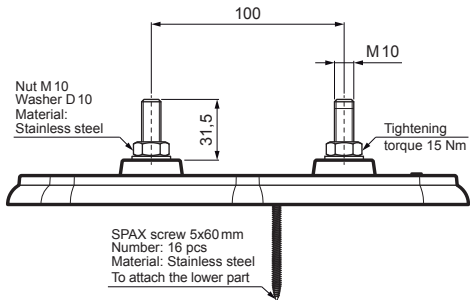

**DETAIL:**  
1. mounting plate basic

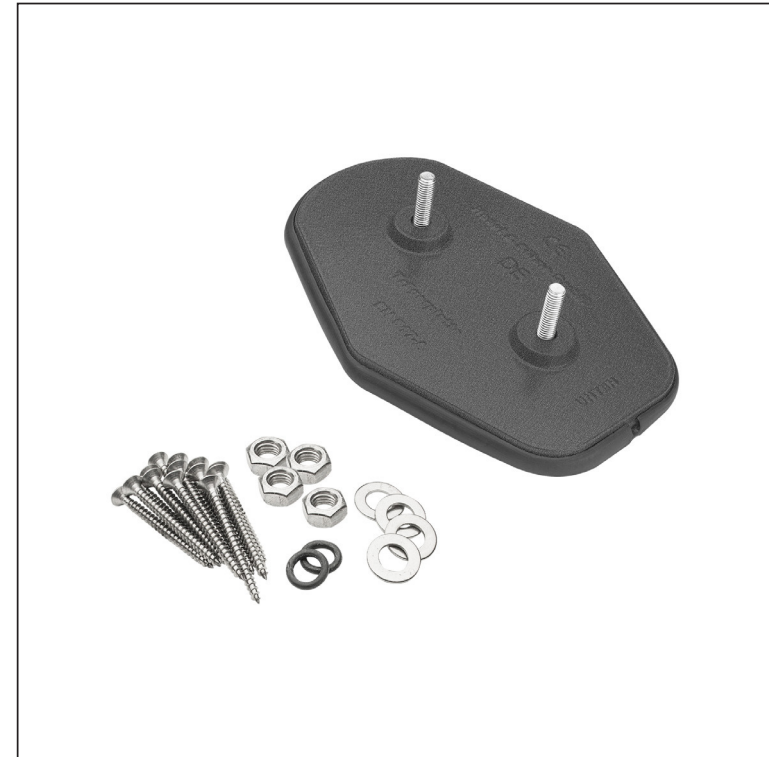
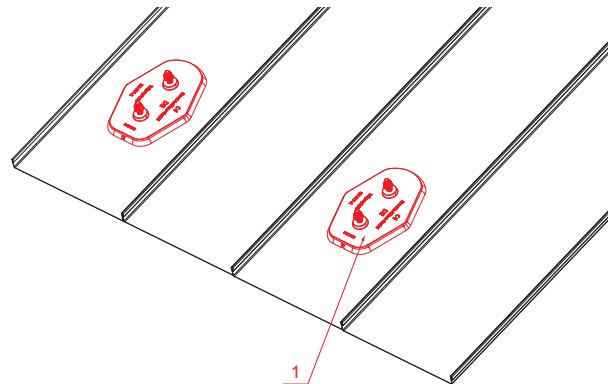

**ANM** Aluminium pre-painted W.15 – Anthracite W.15 – RAL 7016

INDEX	CHANGE	DATE	SIGNATURE	<b>KJG</b> QUALITY®	Scan code for 3D model	
MATERIAL BRAND			W.C.	WEIGHT kg	SCALE	
SIZE, SEMI-FINISHED PRODUCTS				STN STANDARD	SORTING NUMBER	
AUXILIARY EQUIPMENT				NOTE	POSITION NUMBER	
ELABORATED BY Ing. Kluska M.						
TESTED BY						
TECHNOLOGIST		TECHNOLOGIST		OLD DRAWING	DRAWING NUMBER	
NAME				Number of sheets		
Mounting plate basic				FALZ-HEU MP ZPL Sheet		

Created: 20.01.2026 07:43:40

Technical changes reserved