

TECHNICAL SHEET

EXTENSION FOR SNOW STOPPER PIPE HOLDER FOR FALZ ZS-W.15ZSF ND/2

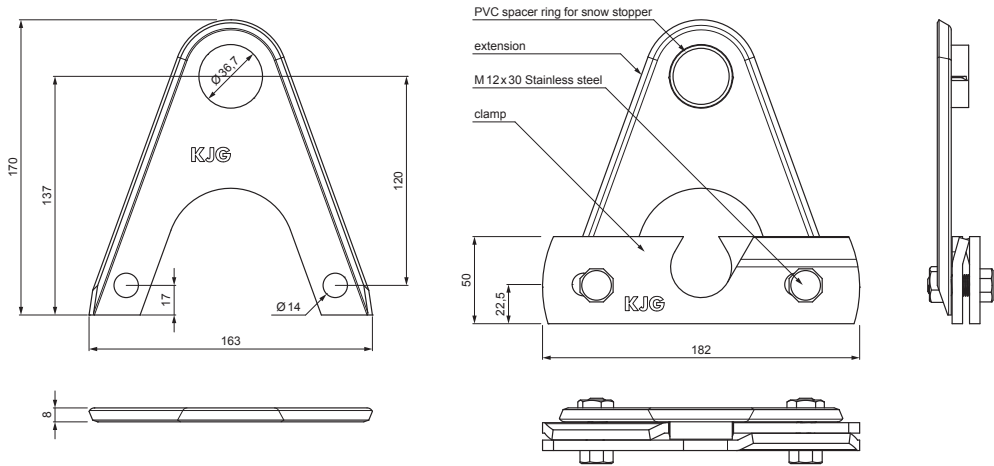

DETAIL:

1. snow stopper clamp for FALZ
2. extension for snow stopper pipe holder for FALZ
3. ice breaker for snow stopper for
4. pipe for snow stopper
5. PVC pipe coupling for snow stopper
6. PVC pipe end cap for snow stopper
7. PVC spacer ring for snow stopper

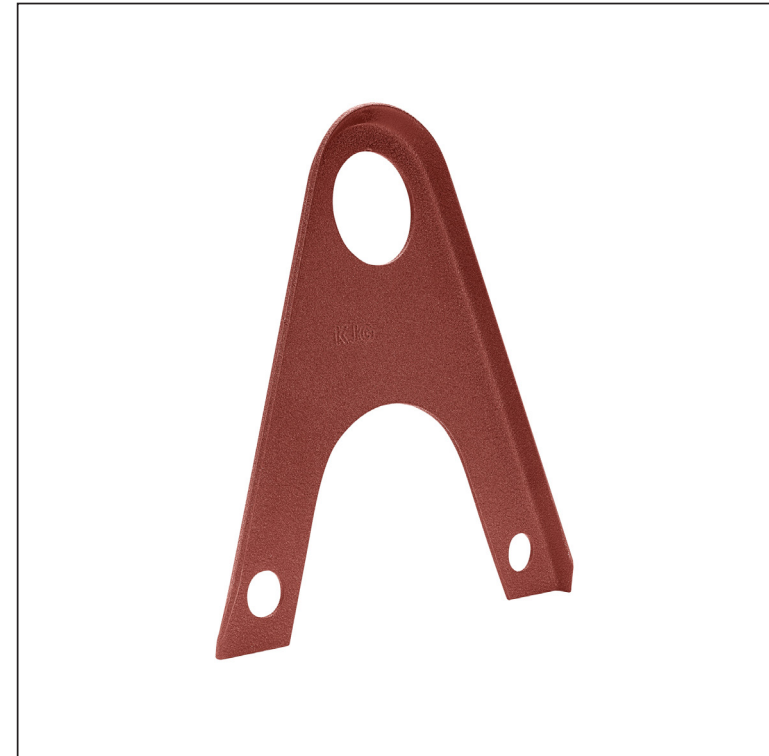
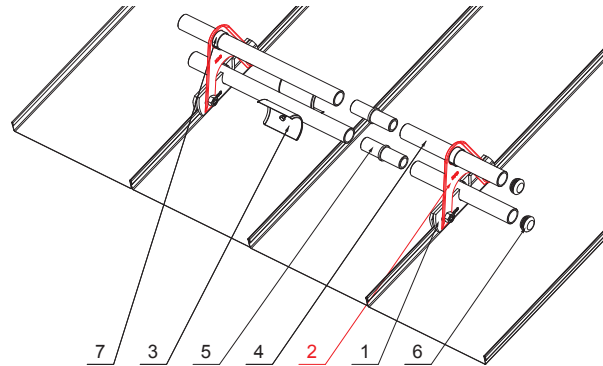

OCM Aluminium pre-painted W.15 – Steel red W.15 – RAL 3009

INDEX	CHANGE	DATE	SIGNATURE	KJG QUALITY®	Scan code for 3D model	
MATERIAL BRAND			W.C.	WEIGHT kg	SCALE	
SIZE, SEMI-FINISHED PRODUCTS				STN STANDARD	SORTING NUMBER	
AUXILIARY EQUIPMENT				NOTE	POSITION NUMBER	
ELABORATED BY Ing. Kluska M.						
TESTED BY						
TECHNOLOGIST		TECHNOLOGIST		OLD DRAWING	DRAWING NUMBER	
NAME				Extension for snow stopper pipe holder for falz		
Number of sheets				ZS-W.15ZSF ND/2		Sheet

Created: 22.04.2026 03:24:46

Technical changes reserved