

TECHNICAL SHEET

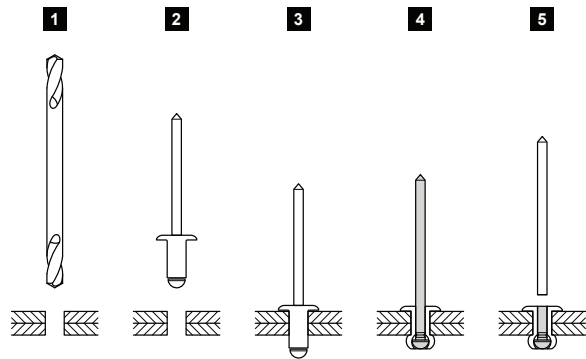

TEAR-OFF RIVET

SM-NO



P Galvanized steel – Natur

Dimensions [mm]				
Nominal dimension	Ø D	Ø D1	L	L1
3,2 x 6	3,2	1,9	6	29
3,2 x 8	3,2	1,9	8	29
3,2 x 10	3,2	1,9	10	29
3,2 x 12	3,2	1,9	12	29
4,0 x 6	4,0	2,4	6	30
4,0 x 8	4,0	2,4	8	30
4,0 x 10	4,0	2,4	10	30
4,0 x 12	4,0	2,4	12	30

INDEX	CHANGE	DATE	SIGNATURE	 	
MATERIAL BRAND			W.C.	WEIGHT kg	SCALE
SIZE, SEMI-FINISHED PRODUCTS			STN STANDARD		SORTING NUMBER
AUXILIARY EQUIPMENT			NOTE		POSITION NUMBER
ELABORATED BY Ing. Kluska M.			OLD DRAWING		DRAWING NUMBER
TESTED BY			TECHNOLOGIST		
NAME			Tear-off rivet		Number of sheets
					SM-NO
					Sheet 

Created: 04.06.2026 13:43:31

Technical changes reserved