

TECHNICAL SHEET

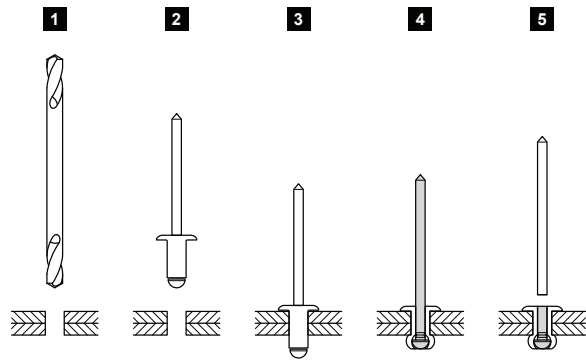

TEAR-OFF RIVET

SM-NO

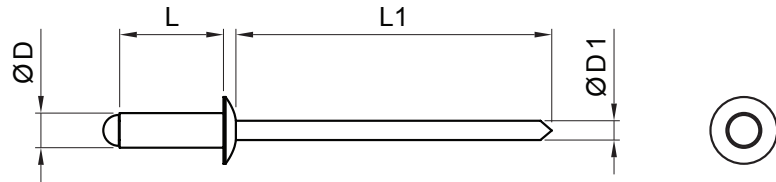

IC Galvanized steel pre-painted – Intense black – RAL 9005

Dimensions [mm]				
Nominal dimension	Ø D	Ø D1	L	L1
3,2 x 6	3,2	1,9	6	29
3,2 x 8	3,2	1,9	8	29
3,2 x 10	3,2	1,9	10	29
4,0 x 6	4,0	2,4	6	30
4,0 x 8	4,0	2,4	8	30
4,0 x 10	4,0	2,4	10	30

INDEX	CHANGE	DATE	SIGNATURE	 	
MATERIAL BRAND			W.C.	WEIGHT kg	SCALE
SIZE, SEMI-FINISHED PRODUCTS				STN STANDARD	SORTING NUMBER
AUXILIARY EQUIPMENT				NOTE	POSITION NUMBER
ELABORATED BY Ing. Kluska M.					
TESTED BY					
TECHNOLOGIST		TECHNOLOGIST		OLD DRAWING	DRAWING NUMBER
NAME			SM-NO		
Tear-off rivet			Number of sheets		Sheet 

Created: 20.04.2026 00:51:42

Technical changes reserved