

TECHNICAL SHEET

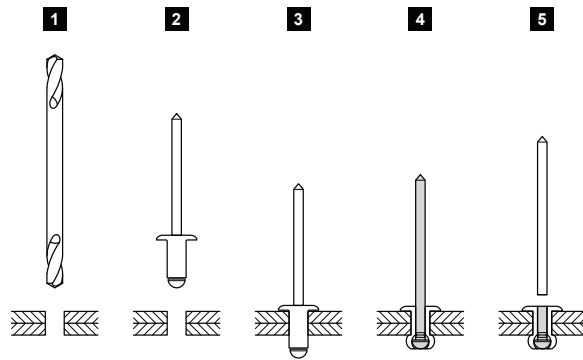



TEAR-OFF RIVET

SM-NO



PS Galvanized steel prepainted – Dusty grey – RAL 7037

Dimensions [mm]				
Nominal dimension	Ø D	Ø D1	L	L1
3,2 x 6	3,2	1,9	6	29
3,2 x 8	3,2	1,9	8	29
3,2 x 10	3,2	1,9	10	29
4,0 x 6	4,0	2,4	6	30
4,0 x 8	4,0	2,4	8	30
4,0 x 10	4,0	2,4	10	30

INDEX CHANGE	DATE	SIGNATURE			
MATERIAL BRAND					
SIZE, SEMI-FINISHED PRODUCTS					
AUXILIARY EQUIPMENT			STN STANDARD		SORTING NUMBER
ELABORATED BY Ing. Kluska M.			NOTE		POSITION NUMBER
TESTED BY					
TECHNOLOGIST		TECHNOLOGIST	OLD DRAWING		DRAWING NUMBER
NAME			Tear-off rivet		
			Number of sheets		SM-NO Sheet 

Created: 20.04.2026 09:37:13

Technical changes reserved