

TECHNICAL SHEET

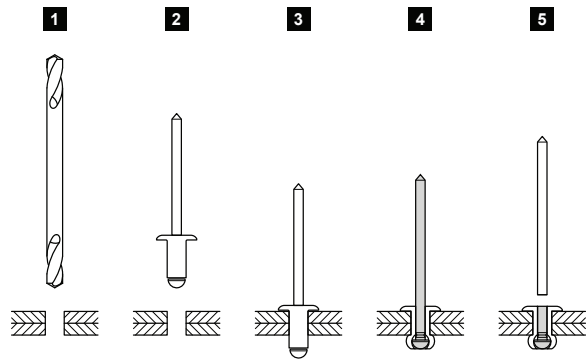



TEAR-OFF RIVET

SM-HNO



AN Aluminium pre-painted – Anthracite – RAL 7016

Dimensions [mm]				
Nominal dimension	Ø D	Ø D1	L	L1
4,0 x 8	4,0	2,2	8	30
4,0 x 10	4,0	2,2	10	30

INDEX	CHANGE	DATE	SIGNATURE			
MATERIAL BRAND			W.C.	WEIGHT kg	SCALE	
SIZE, SEMI-FINISHED PRODUCTS			STN STANDARD		SORTING NUMBER	
AUXILIARY EQUIPMENT			NOTE		POSITION NUMBER	
ELABORATED BY Ing. Kluska M.			OLD DRAWING		DRAWING NUMBER	
TESTED BY			TECHNOLOGIST		DRAWING NUMBER	
NAME			Tear-off rivet		Number of sheets	
					SM-HNO	
					Sheet 	

Created: 07.06.2026 20:26:13

Technical changes reserved