

TECHNICAL SHEET

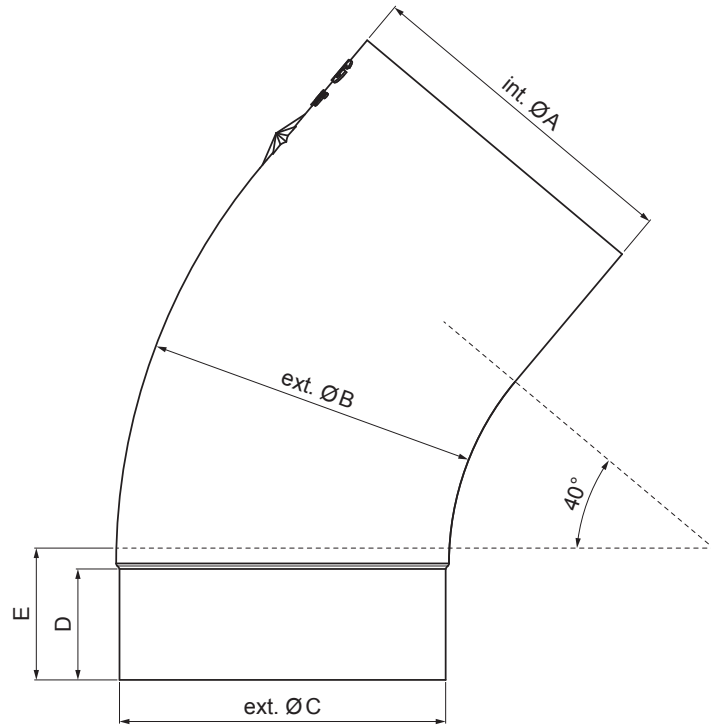

# ELBOW BLIND 40°

# P-PKT



**IC** Galvanized steel prepainted – Intense black – RAL 9005

Dimensions [mm]					
Nominal size	$\text{Ø} A$	$\text{Ø} B$	$\text{Ø} C$	D	E
80	80,4	79	76,9	28	40
100	100,4	99,0	96,8	35	50
120	120,3	119,0	116,7	42	60

INDEX	CHANGE	DATE	SIGNATURE		
MATERIAL BRAND			W.C.	WEIGHT kg	SCALE
SIZE, SEMI-FINISHED PRODUCTS				STN STANDARD	SORTING NUMBER
AUXILIARY EQUIPMENT				NOTE	POSITION NUMBER
ELABORATED BY Ing. Kluska M.					
TESTED BY					
TECHNOLOGIST		TECHNOLOGIST		OLD DRAWING	DRAWING NUMBER
NAME			Elbow blind 40°		
			Number of sheets	P-PKT	Sheet 

Created: 06.06.2026 06:53:10

Technical changes reserved