

TECHNICAL SHEET

DOWNPIPE BRACKET WITH THREAD M 10

M-MOB

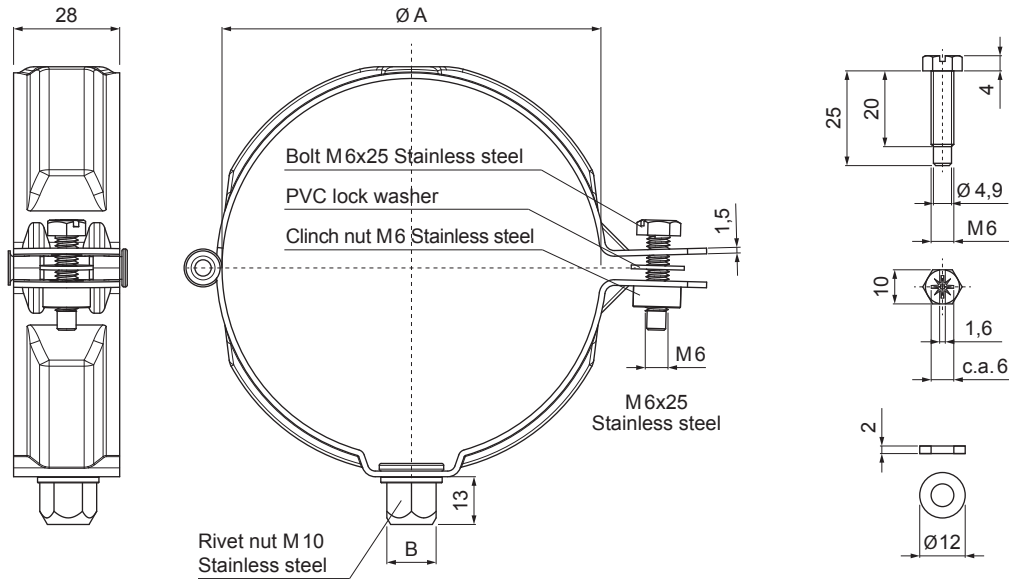

M Copper – Natur

Dimensions [mm]		
Nominal size	Ø A	B
60	60	13
80	80	13
100	100	13
120	120	13
150	150	13

INDEX	CHANGE	DATE	SIGNATURE	KJG QUALITY®	Scan code for 3D model
MATERIAL BRAND			W.C.	WEIGHT kg	SCALE
SIZE, SEMI-FINISHED PRODUCTS				STN STANDARD	SORTING NUMBER
AUXILIARY EQUIPMENT				NOTE	POSITION NUMBER
ELABORATED BY Ing. Kluska M.					
TESTED BY					
TECHNOLOGIST		TECHNOLOGIST		OLD DRAWING	DRAWING NUMBER
NAME Downpipe bracket with thread M 10				Number of sheets	M-MOB Sheet

Created: 04.06.2026 16:12:29

Technical changes reserved