

TECHNICAL SHEET

# WATER COLLECTOR WITH HOSE AND KNOB

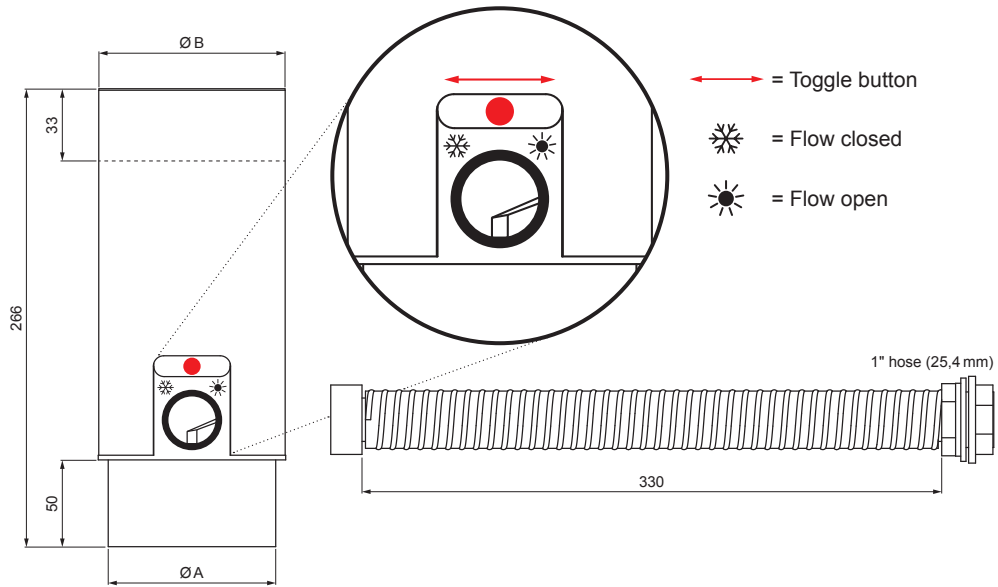

# W-WZVHAG



**B** Aluminium pre-painted – Pure white – RAL 9010



Dimensions [mm]		
Nominal size	A	B
80	77	81
100	97	101

INDEX	CHANGE	DATE	SIGNATURE	 	
MATERIAL BRAND			W.C.	WEIGHT kg	SCALE
SIZE, SEMI-FINISHED PRODUCTS			STN STANDARD		SORTING NUMBER
AUXILIARY EQUIPMENT			NOTE		POSITION NUMBER
ELABORATED BY Ing. Kluska M.			OLD DRAWING		DRAWING NUMBER
TESTED BY			NAME		
TECHNOLOGIST			Water Collector with hose and knob		Number of sheets
					W-WZVHAG Sheet 

Created: 05.06.2026 22:19:33

Technical changes reserved