

TECHNICAL SHEET

WATER COLLECTOR WITH HOSE AND KNOB

W.15-WZVHAG

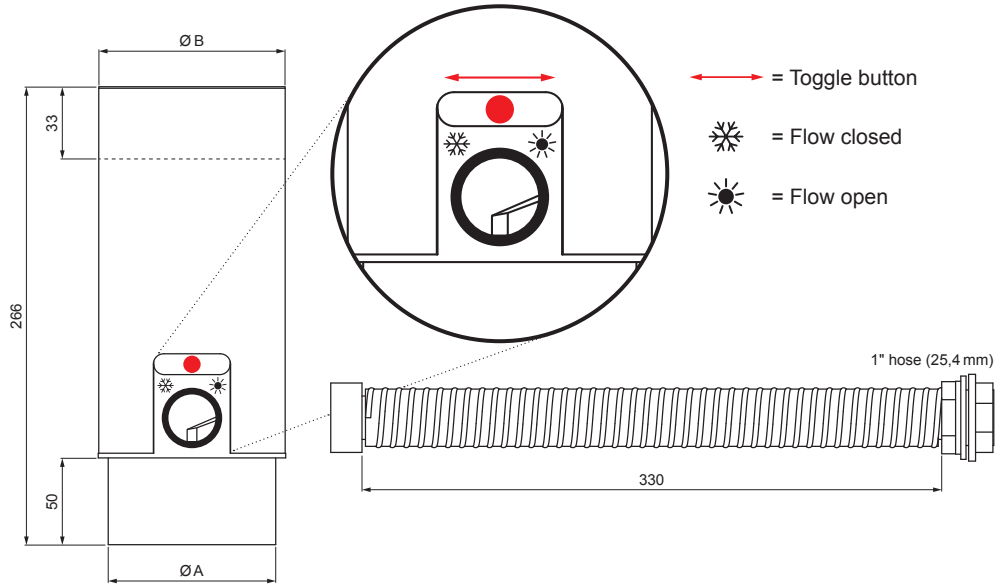

MHM Aluminium pre-painted W.15 – Copper brown W.15 – RAL 8004



Dimensions [mm]		
Nominal size	A	B
80	77	81
100	97	101

INDEX	CHANGE	DATE	SIGNATURE	KJG QUALITY®	Scan code for 3D model
MATERIAL BRAND			W.C.	WEIGHT kg	SCALE
SIZE, SEMI-FINISHED PRODUCTS				STN STANDARD	SORTING NUMBER
AUXILIARY EQUIPMENT				NOTE	POSITION NUMBER
ELABORATED BY Ing. Kluska M.				OLD DRAWING	DRAWING NUMBER
TESTED BY					
TECHNOLOGIST		TECHNOLOGIST		Number of sheets	W.15-WZVHAG Sheet
NAME			Water Collector with hose and knob		

Created: 04.06.2026 08:55:12

Technical changes reserved