

TECHNICAL SHEET

PERKEO CU TIP 350 g

KNS-PERKE CU SPIC

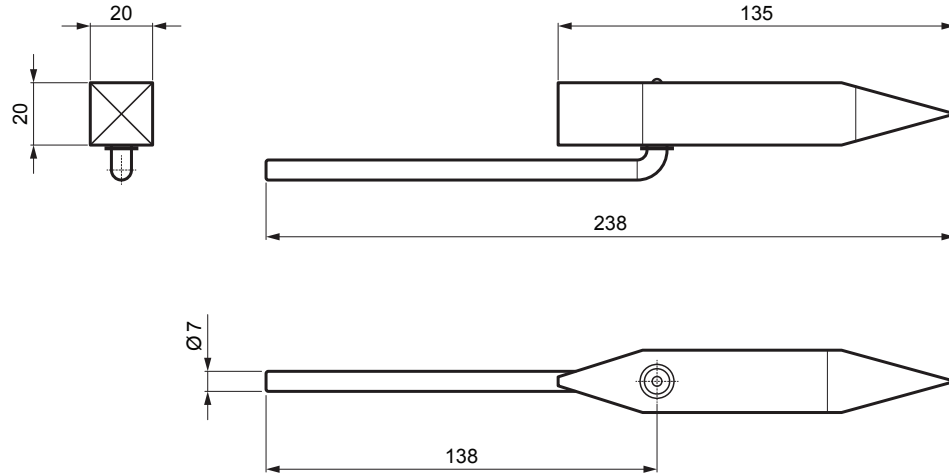

DESCRIPTION:

- PERKEO soldering copper tip weighing 350g with marking 209/2
- made of cold-rolled electrolytic copper
- long service life thanks to high compressed copper
- due to the use of cold-rolled electrolytic copper as the basic material, the Soldering tips have high thermal conductive and storage capacity
- due to that the tip is heated to working temperature in less than 45 seconds
- the basic material ensures maximum heat accumulation, which also means less gas consumption during electricity

APPLICATION:

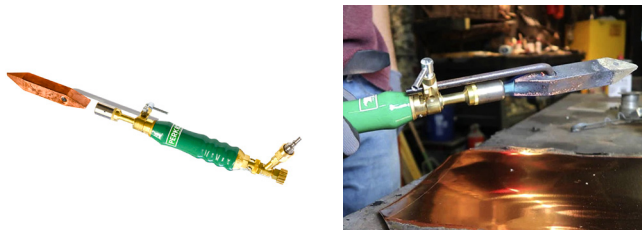

M Copper

INDEX	CHANGE	DATE	SIGNATURE		
MATERIAL BRAND			W.C.	WEIGHT kg	SCALE
SIZE, SEMI-FINISHED PRODUCTS				STN STANDARD	SORTING NUMBER
AUXILIARY EQUIPMENT				NOTE	POSITION NUMBER
ELABORATED BY Ing. Kluska M.					
TESTED BY					
TECHNOLOGIST		TECHNOLOGIST		OLD DRAWING	DRAWING NUMBER
NAME				KNS-PERKE CU SPIC	
PERKEO CU tip 350 g				Number of sheets	Sheet

Created: 05.06.2026 17:40:58

Technical changes reserved