

TECHNICAL SHEET

SOLDERING HAMMER 325 g

KNS-MASC LKH SPECIAL

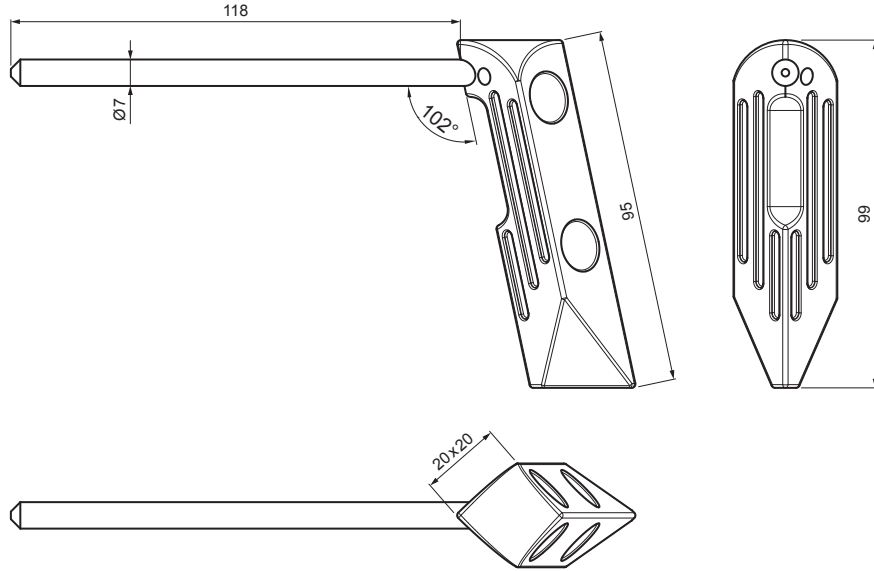

DESCRIPTION:

- soldering hammer from the German company **MASC** with marking **LKH SPECIAL**
- long-lasting surface treatment provides increased service life and durability
- working temperature reached in 45 seconds
- very good heat accumulation, i.e. longer heat accumulation capacity
- low gas consumption
- no pre-tinning, filing or forging required
- clean only with a damp cloth, do not rinse with water
- do not use hydrochloric acid!
- weight: 325 g

DETAIL:



INDEX	CHANGE	DATE	SIGNATURE		
MATERIAL BRAND			W.C.	WEIGHT kg	SCALE
SIZE, SEMI-FINISHED PRODUCTS				STN STANDARD	SORTING NUMBER
AUXILIARY EQUIPMENT				NOTE	POSITION NUMBER
ELABORATED BY Ing. Kluska M.					
TESTED BY					
TECHNOLOGIST		TECHNOLOGIST		OLD DRAWING	DRAWING NUMBER
NAME				KNS-MASC LKH SPECIAL	
Soldering hammer 325 g				Number of sheets	Sheet

Created: 05.06.2026 17:41:42

Technical changes reserved