

TECHNICAL SHEET

DOWNPIPE CONNECTOR

P-PSRU

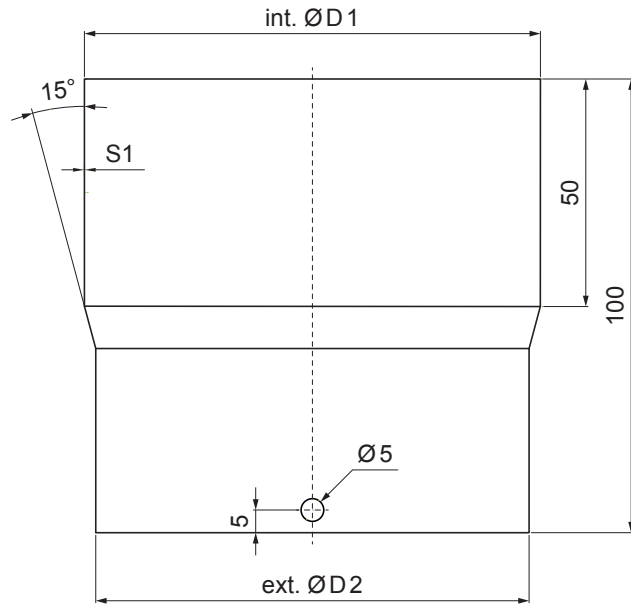

AN Galvanized steel prepainted – Anthracite – RAL 7016

INDEX	CHANGE	DATE	SIGNATURE	KJG QUALITY®	Scan code for 3D model
MATERIAL BRAND			W.C.	WEIGHT kg	SCALE
SIZE, SEMI-FINISHED PRODUCTS				STN STANDARD	SORTING NUMBER
AUXILIARY EQUIPMENT				NOTE	POSITION NUMBER
ELABORATED BY Ing. Kluska M.					
TESTED BY				OLD DRAWING	DRAWING NUMBER
TECHNOLOGIST			TECHNOLOGIST		
NAME			P-PSRU		
Spojka zvodovej rúry			Number of sheets		Sheet

Created: 06.03.2026 13:14:18

Technical changes reserved

Dimensions [mm]		
Nominal size	int. Ø D 1	ext. Ø D 2
80	80	76
100	100	96
120	120	116