

TECHNICAL SHEET

DOWNPIPE CONNECTOR

P-PSRU

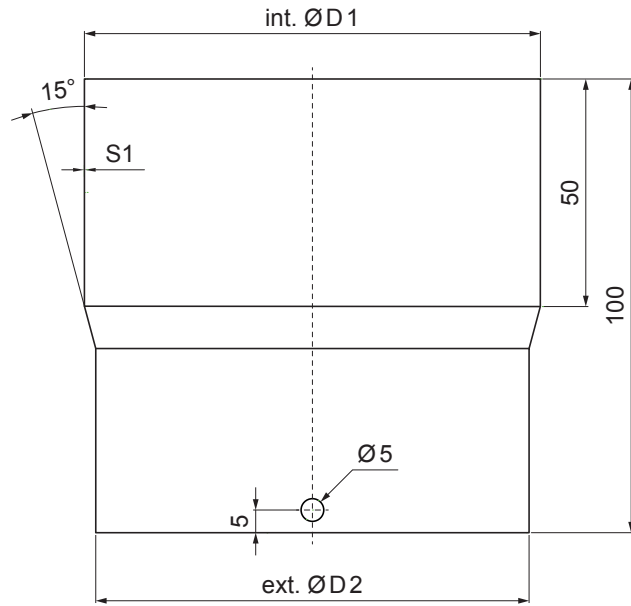

IC Galvanized steel prepainted – Intense black – RAL 9005

Dimensions [mm]		
Nominal size	int. Ø D 1	ext. Ø D 2
80	80	76
100	100	96
120	120	116

INDEX	CHANGE	DATE	SIGNATURE	KJG QUALITY®	Scan code for 3D model
MATERIAL BRAND			W.C.	WEIGHT kg	SCALE
SIZE, SEMI-FINISHED PRODUCTS			STN STANDARD		SORTING NUMBER
AUXILIARY EQUIPMENT			NOTE		POSITION NUMBER
ELABORATED BY Ing. Kluska M.			OLD DRAWING		DRAWING NUMBER
TESTED BY			NAME		
TECHNOLOGIST			Spojka zvodovej rúry		Number of sheets
			P-PSRU		Sheet

Created: 06.06.2026 10:51:30

Technical changes reserved