

TECHNICAL SHEET

# DOWNPIPE CONNECTOR

# P-PSRU

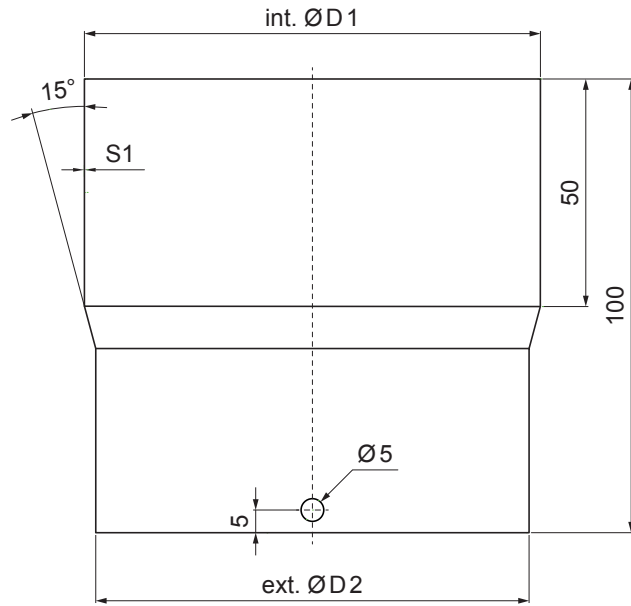

**MZ** Galvanized steel prepainted – Moss green – RAL 6005

Dimensions [mm]		
Nominal size	int. Ø D 1	ext. Ø D 2
80	80	76
100	100	96
120	120	116

INDEX	CHANGE	DATE	SIGNATURE	<b>KJG</b> QUALITY®	Scan code for 3D model
MATERIAL BRAND			W.C.	WEIGHT kg	SCALE
SIZE, SEMI-FINISHED PRODUCTS			STN STANDARD		SORTING NUMBER
AUXILIARY EQUIPMENT			NOTE		POSITION NUMBER
ELABORATED BY Ing. Kluska M.			OLD DRAWING		DRAWING NUMBER
TESTED BY			NAME		
TECHNOLOGIST			Spojka zvodovej rúry		
			Number of sheets		P-PSRU Sheet

Created: 06.06.2026 17:39:58

Technical changes reserved