

TECHNICAL SHEET

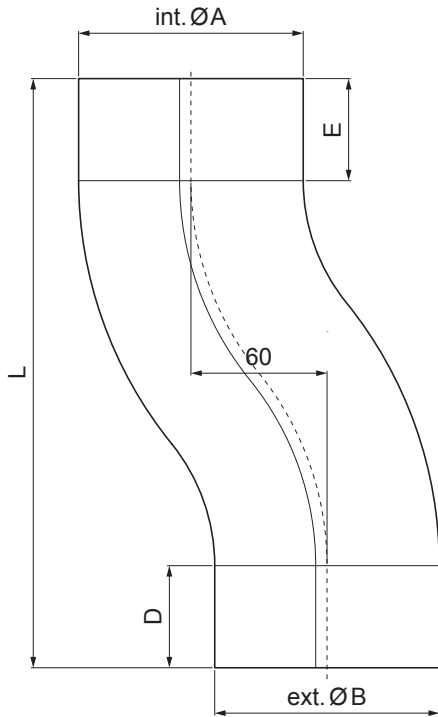

DOUBLE ELBOW

P-PKO



BHT Galvanized steel prepainted – Grey aluminum P.20 – RAL 9007

Dimensions [mm]					
Nominal size	$\varnothing A$	$\varnothing B$	D	E	L
80	80,4	79,0	35	35	219
100	100,4	99,0	35	35	240
120	120,4	119,0	40	40	268

INDEX	CHANGE	DATE	SIGNATURE		
MATERIAL BRAND			W.C.	WEIGHT kg	SCALE
SIZE, SEMI-FINISHED PRODUCTS				STN STANDARD	SORTING NUMBER
AUXILIARY EQUIPMENT				NOTE	POSITION NUMBER
ELABORATED BY Ing. Kluska M.				OLD DRAWING	DRAWING NUMBER
TESTED BY					
TECHNOLOGIST		TECHNOLOGIST		Number of sheets	P-PKO Sheet 
NAME			Double elbow		

Created: 04.06.2026 09:07:48

Technical changes reserved