

TECHNICAL SHEET

# RIGHT EDGE TILE DANUBIA

# TER-DANI AN SKKRP

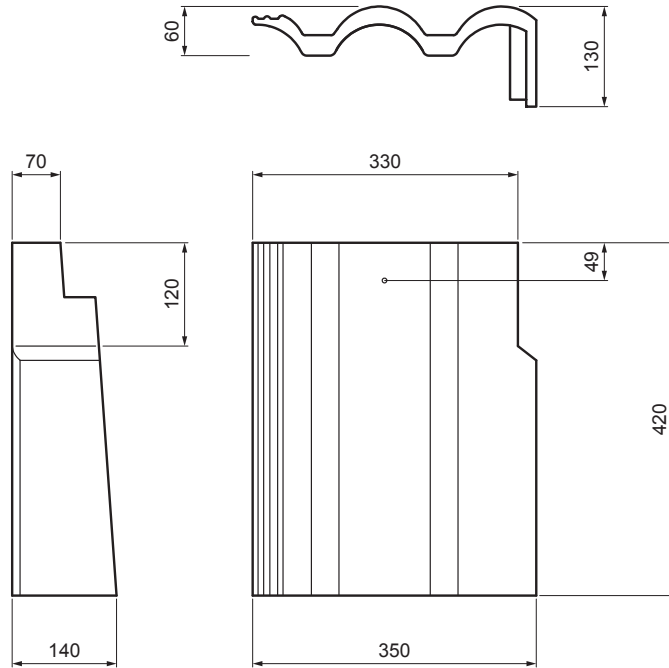

**AN** Colour : Anthracite  
Surface treatment: INOVA

Technical parameters	
Dimensions	350 x 420 mm
Covering width	350 – 420 mm
Component consumption	2,9 – 3,3 pcs/lm
Possibility of application	with batten spacing of 30,5 – 34 cm
Weight	6,90 kg/pcs
Packaging	28 pcs

INDEX	DATE	SIGNATURE	<b>KJG</b> QUALITY ®	TERRAN FABRIKA SVET STROICH
CHANGE				
MATERIAL BRAND	W.C.	WEIGHT kg	SCALE	
SIZE, SEMI-FINISHED PRODUCTS		STN STANDARD	SORTING NUMBER	
AUXILIARY EQUIPMENT		NOTE	POSITION NUMBER	
ELABORATED BY Ing. Kluska M.				
TESTED BY	TECHNOLOGIST	OLD DRAWING	DRAWING NUMBER	
NAME	Right edge tile DANUBIA		Number of sheets	TER-DANI AN SKKRP Sheet

Created: 02.06.2026 17:52:05

Technical changes reserved