

TECHNICAL SHEET

WATER DISTRIBUTORS

P-PRV

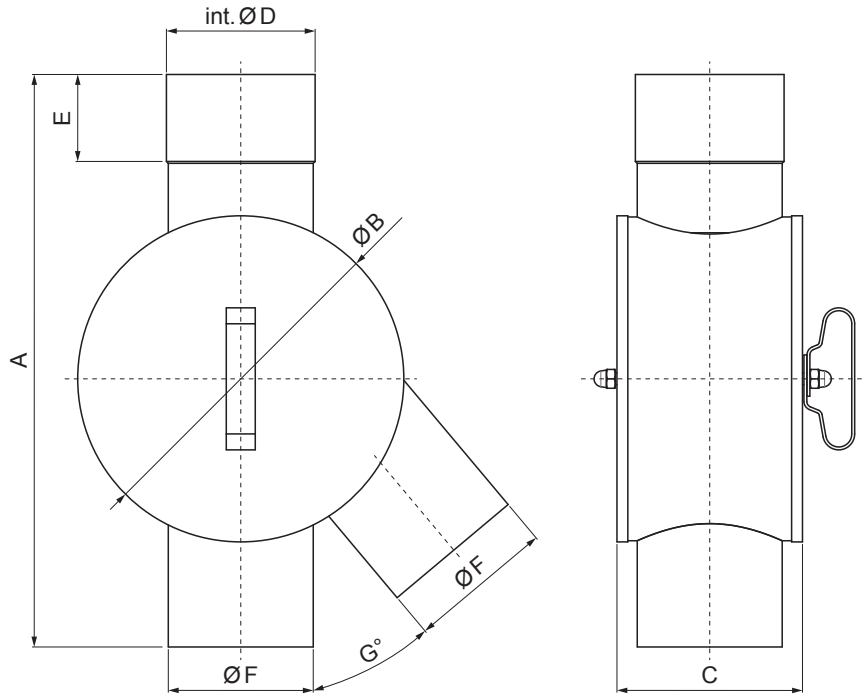

BHT Galvanized steel prepainted – Grey aluminum P.20 – RAL 9007

Dimensions [mm]								
Nominal size	A	ØB	C	int. ØD	E	ØF	G	overflow
80	335	180	108	81	55	80	40	5,9 l/s
100	395	225	128	101	60	100	40	10,7 l/s
120	385	225	140	121	60	120	60	17,4 l/s

INDEX	CHANGE	DATE	SIGNATURE	KJG QUALITY®	Scan code for 3D model	
MATERIAL BRAND			W.C.	WEIGHT kg	SCALE	
SIZE, SEMI-FINISHED PRODUCTS					STN STANDARD	SORTING NUMBER
AUXILIARY EQUIPMENT					NOTE	POSITION NUMBER
ELABORATED BY Ing. Kluska M.						
TESTED BY						
TECHNOLOGIST		TECHNOLOGIST			OLD DRAWING	DRAWING NUMBER
NAME			Water distributors		Number of sheets	P-PRV Sheet

Created: 06.06.2026 00:09:19

Technical changes reserved