

TECHNICAL SHEET

DOWNPIPE FLAP

M-MZV

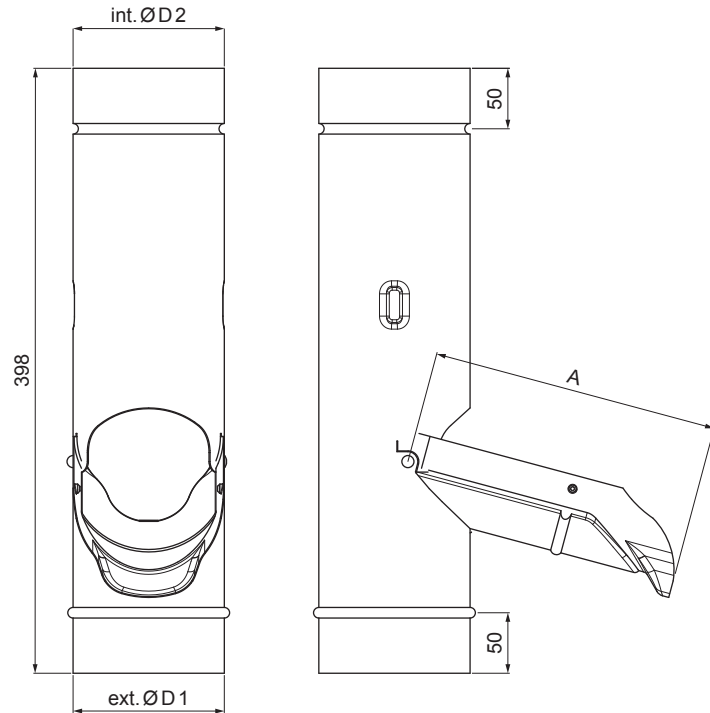

M Copper – Natur

INDEX	CHANGE	DATE	SIGNATURE	KJG QUALITY®	Scan code for 3D model
MATERIAL BRAND			W.C.	WEIGHT kg	SCALE
SIZE, SEMI-FINISHED PRODUCTS				STN STANDARD	SORTING NUMBER
AUXILIARY EQUIPMENT				NOTE	POSITION NUMBER
ELABORATED BY Ing. Kluska M.					
TESTED BY					
TECHNOLOGIST		TECHNOLOGIST		OLD DRAWING	DRAWING NUMBER
NAME Downpipe flap				Number of sheets	M-MZV Sheet

Created: 04.06.2026 17:41:25

Technical changes reserved

Dimensions [mm]			
Nominal size	A	ØD1	ØD2
80	150	80	80
100	190	100	100