

TECHNICAL SHEET

# BARGE FLASHING

# UNI-PKLE

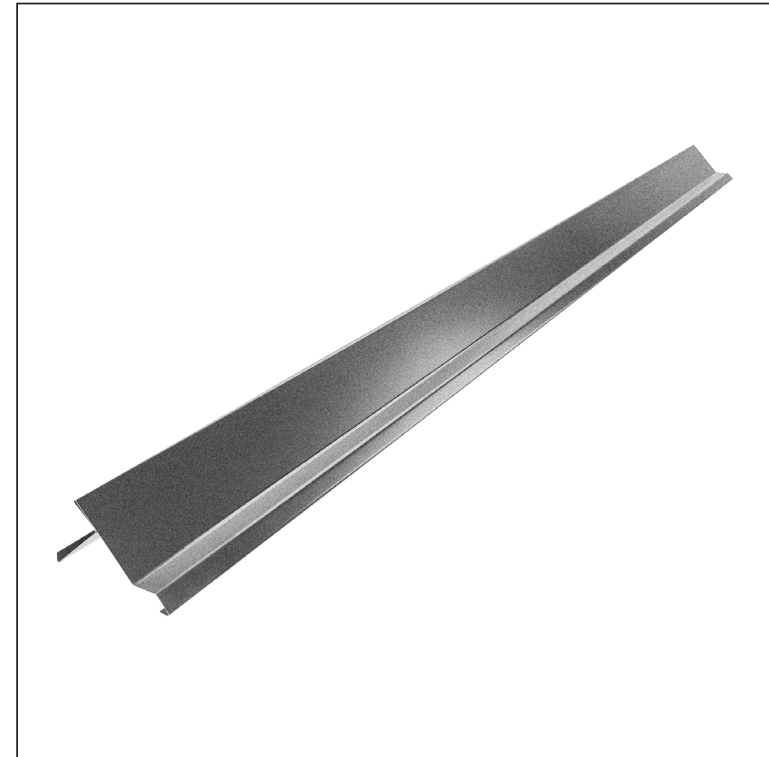
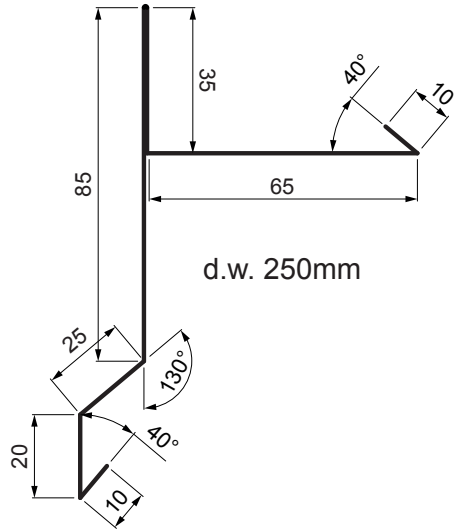

**DETAIL:**

- 1. barge flashing
- 2. farmer screw 4,8x20
- 3. metal roofing
- 4. roof battens
- 5. battens / air gap
- 6. rafter
- 7. gable plate
- 8. foil / waterproofing insulation

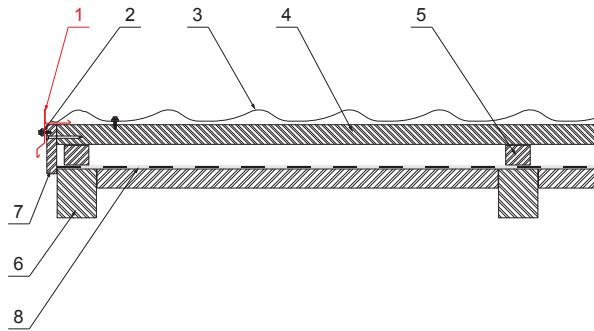

**ANM** Galvanized steel pre-painted MATT – Anthracite MATT – RAL 7016

INDEX	CHANGE	DATE	SIGNATURE	<b>KJG</b> QUALITY®	Scan code for 3D model	
MATERIAL BRAND			W.C.	WEIGHT kg	SCALE	
SIZE, SEMI-FINISHED PRODUCTS				STN STANDARD	SORTING NUMBER	
AUXILIARY EQUIPMENT				NOTE	POSITION NUMBER	
ELABORATED BY Ing. Kluska M.						
TESTED BY				OLD DRAWING	DRAWING NUMBER	
TECHNOLOGIST			TECHNOLOGIST			
NAME			Barge flashing		Number of sheets	UNI-PKLE Sheet

Dimensions	
Nominal dimension [mm]	Length [m]
250	2,0
250	3,0

Created: 04.06.2026 01:21:35

Technical changes reserved