

TECHNICAL SHEET

DOWNPIPE BRACKET WITH PIN 200 MM

P-POD

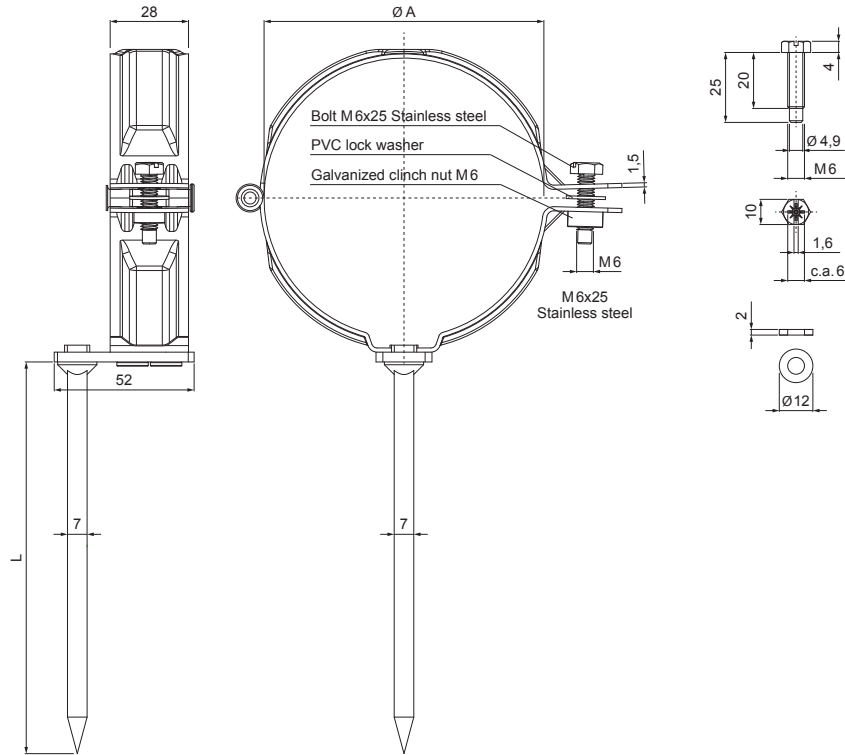

SB Galvanized steel prepainted – Grey white – RAL 9002

Dimensions [mm]		
Nominal size	Ø A	L
80	80	200
100	100	200

INDEX	CHANGE	DATE	SIGNATURE	KJG QUALITY®	Scan code for 3D model
MATERIAL BRAND			W.C.	WEIGHT kg	SCALE
SIZE, SEMI-FINISHED PRODUCTS				STN STANDARD	SORTING NUMBER
AUXILIARY EQUIPMENT				NOTE	POSITION NUMBER
ELABORATED BY Ing. Kluska M.				OLD DRAWING	DRAWING NUMBER
TESTED BY					
TECHNOLOGIST			TECHNOLOGIST		
NAME			P-POD		
Downpipe bracket with pin 200 mm			Number of sheets		Sheet

Created: 07.06.2026 09:25:40

Technical changes reserved