

TECHNICAL SHEET

# DOWNPIPE BRACKET WITH PIN 300 MM

# P-PODD

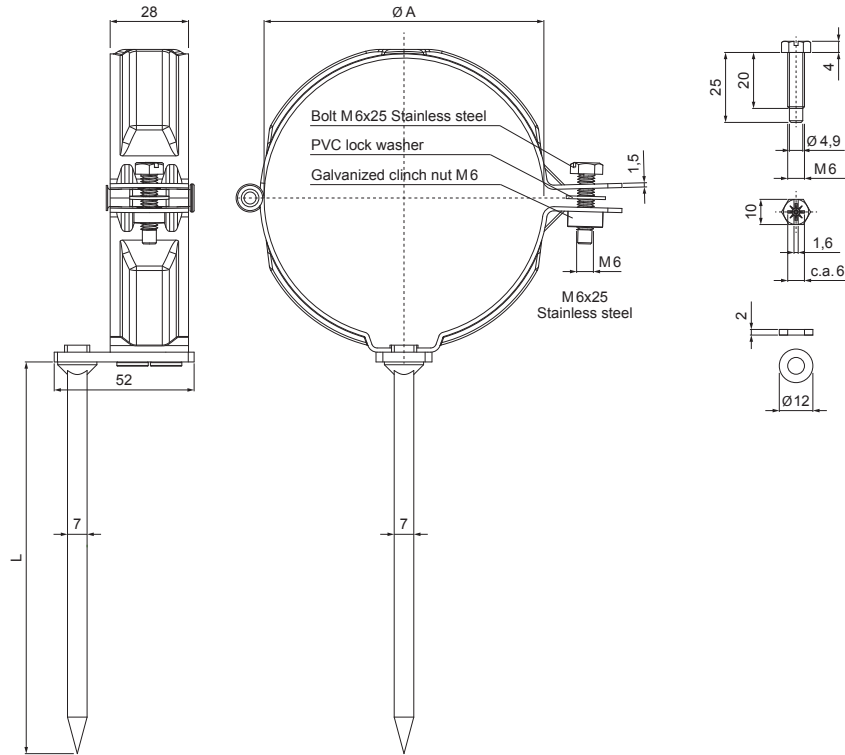

**TM** Galvanized steel pre-painted – Testa di Moro – RAL 8028

INDEX	CHANGE	DATE	SIGNATURE	<b>KJG</b> QUALITY®	Scan code for 3D model
MATERIAL BRAND			W.C.	WEIGHT kg	SCALE
SIZE, SEMI-FINISHED PRODUCTS				STN STANDARD	SORTING NUMBER
AUXILIARY EQUIPMENT				NOTE	POSITION NUMBER
ELABORATED BY Ing. Kluska M.				OLD DRAWING	DRAWING NUMBER
TESTED BY					
TECHNOLOGIST		TECHNOLOGIST		Number of sheets	P-PODD Sheet
NAME Downpipe bracket with pin 300 mm					

Created: 06.06.2026 09:46:10

Technical changes reserved

Dimensions [mm]		
Nominal size	Ø A	L
100	100	300