

TECHNICAL SHEET

DOWNPIPE FLAP

P-PZV

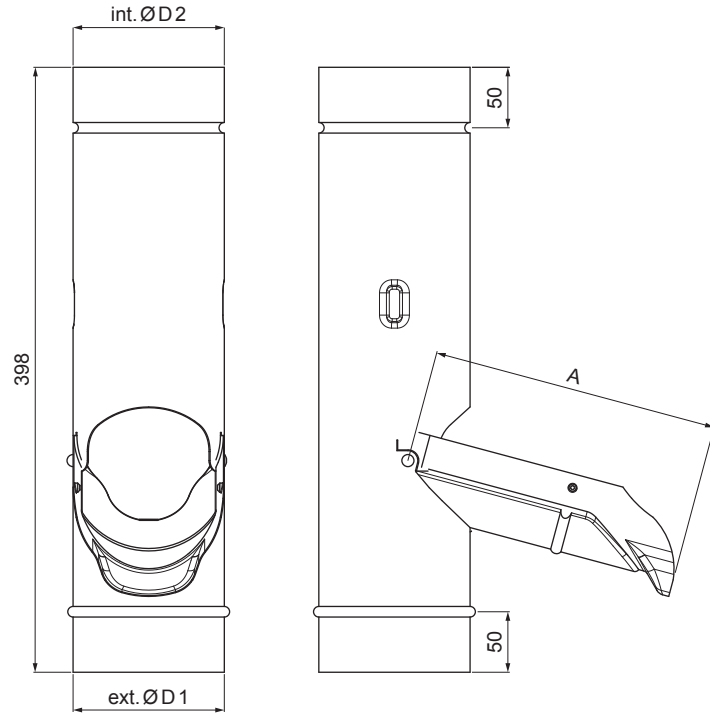

OC Galvanized steel pre-painted – Steel red – RAL 3009

Dimensions [mm]			
Nominal size	A	ØD 1	ØD 2
80	150	80	80
100	190	100	100
120	230	120	120

INDEX	CHANGE	DATE	SIGNATURE	KJG QUALITY®	Scan code for 3D model
MATERIAL BRAND			W.C.	WEIGHT kg	SCALE
SIZE, SEMI-FINISHED PRODUCTS				STN STANDARD	SORTING NUMBER
AUXILIARY EQUIPMENT				NOTE	POSITION NUMBER
ELABORATED BY Ing. Kluska M.					
TESTED BY					
TECHNOLOGIST		TECHNOLOGIST		OLD DRAWING	DRAWING NUMBER
NAME Downpipe flap				Number of sheets	P-PZV Sheet

Created: 04.06.2026 12:15:41

Technical changes reserved