

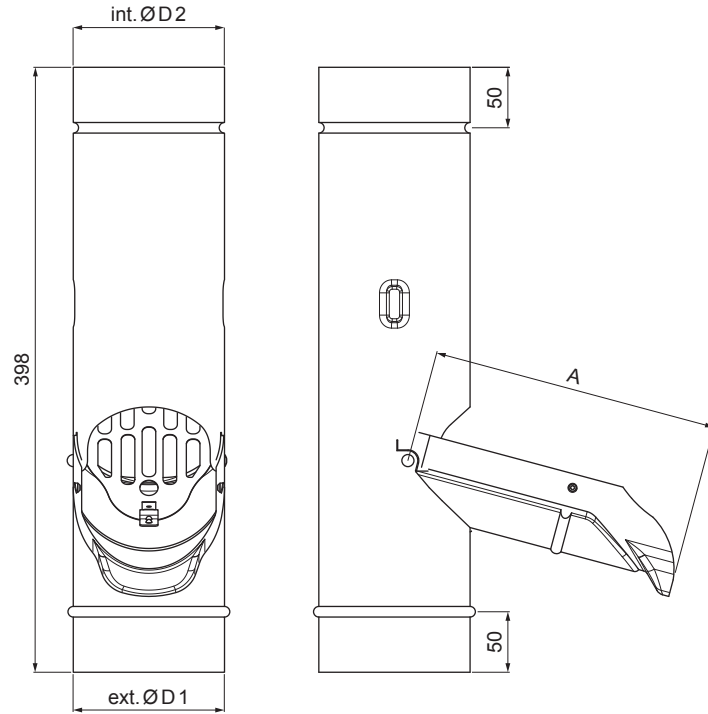

TECHNICAL SHEET

DOWNPIPE FLAP WITH SIEVE

P-PZVS



SB Galvanized steel prepainted – Grey white – RAL 9002

| | | | | | |
|----------------------------------|--------|--------------|-----------|------------------------|--|
| INDEX | CHANGE | DATE | SIGNATURE | KJG QUALITY® | Scan code for 3D model  |
| | | | | | |
| MATERIAL BRAND | | | W.C. | WEIGHT kg | SCALE |
| SIZE, SEMI-FINISHED PRODUCTS | | | | STN STANDARD | SORTING NUMBER |
| AUXILIARY EQUIPMENT | | | | NOTE | POSITION NUMBER |
| ELABORATED BY Ing. Kluska M. | | | | | |
| TESTED BY | | | | | |
| TECHNOLOGIST | | TECHNOLOGIST | | OLD DRAWING | DRAWING NUMBER |
| NAME Downpipe flap with sieve | | | | Number of sheets | P-PZVS Sheet  |

Created: 07.06.2026 09:25:41

Technical changes reserved

| Dimensions [mm] | | | |
|-----------------|-----|------|------|
| Nominal size | A | ØD 1 | ØD 2 |
| 80 | 150 | 80 | 80 |
| 100 | 190 | 100 | 100 |
| 120 | 230 | 120 | 120 |